

## ROCKWALL CITY COUNCIL MEETING

Monday, December 2, 2024 - 5:30 PM

City Hall Council Chambers - 385 S. Goliad St., Rockwall, TX 75087

**I. Call Public Meeting to Order**

**II. Executive Session**

The City of Rockwall City Council will recess into executive session to discuss the following matter as authorized by chapter 551 of the Texas government code:

1. Discussion regarding (re)appointments to city boards and commissions, pursuant to §551.074 (Personnel Matters).
2. Discussion regarding possible City Charter amendments and related legal advice, pursuant to §Section 551.071 (Consultation with Attorney)
3. Discussion regarding possible sale/purchase/lease of real property in the vicinity of downtown, pursuant to Section §551.072 (Real Property) and Section §551.071 (Consultation with Attorney).

**III. Adjourn Executive Session**

**IV. Reconvene Public Meeting (6:00 P.M.)**

**V. Invocation and Pledge of Allegiance - Councilmember Campbell**

**VI. Proclamations / Awards / Recognitions**

1. "Life Saving Award" - Rockwall Police Department (Officer Mitchell Attaway)

**VII. Open Forum**

This is a time for anyone to address the Council and public on any topic not already listed on the agenda or set for a public hearing. To speak during this time, please turn in a (yellow) "Request to Address City Council" form to the City Secretary either before the meeting or as you approach the podium. Per Council policy, public comments should be limited to three (3) minutes out of respect for others' time. On topics raised during Open Forum, please know Council is not permitted to respond to your comments during the meeting since the topic has not been specifically listed on the agenda (the Texas Open Meetings Act requires that topics of discussion/deliberation be posted on an agenda not less than 72 hours in advance of the Council meeting). This, in part, is so that other citizens who may have the same concern may also be involved in the discussion.

**VIII. Take Any Action as a Result of Executive Session**

**IX. Consent Agenda**

These agenda items are routine/administrative in nature, have previously been discussed at a prior City Council meeting, and/or they do not warrant Council deliberation. If you would like to discuss one of these items, please do so during "Open Forum."

1. Consider approval of the minutes from the November 18, 2024 city council meeting, and take any action necessary.
2. **Z2024-049** - Consider a request by Renee Ward, PE of Weir & Associates, Inc. on behalf of Conor Keilty, AIA of Structured REA-Rockwall Land, LLC for the approval of an **ordinance** for a Specific Use Permit (SUP) for a *Residence Hotel* on a 2.819-acre portion of a larger 4.767-acre parcel of land identified as Lot 6, Block B, Fit Sport Life Addition, City of Rockwall, Rockwall County, Texas, zoned Commercial (C) District, situated within the FM-549 Overlay (FM-549 OV) District, generally located east of the intersection of FM-549 and Fit Sport Life Boulevard, and take any action necessary **(2nd Reading)**.
3. **Z2024-050** - Consider a request by Jim Joyce on behalf of JFI Series 1, LLC for the approval of an **ordinance** for a Specific Use Permit (SUP) for *Residential Infill Adjacent to an Established Subdivision* on a 0.1340-acre parcel of land identified as Lot 5A-R of the Lofland Addition, City of Rockwall, Rockwall County, Texas, zoned Two-Family (2F) District, generally located on the west side of Bost Street north of the intersection of St. Mary's Street and Bost Street, and take any action necessary **(2nd Reading)**.
4. **Z2024-051** - Consider a request by Jim Joyce on behalf of JFI Series 1, LLC for the approval of an **ordinance** for a Specific Use Permit (SUP) for Residential Infill Adjacent to an Established Subdivision on a 0.1340-acre parcel of land identified as Lot 6A-R of the Lofland Addition, City of Rockwall, Rockwall County, Texas, zoned Two-Family (2F) District, generally located on the west side of Bost Street north of the intersection of St. Mary's Street and Bost Street, and take any action necessary **(2nd Reading)**.
5. **P2024-037** - Consider a request by Frank Conselman of Conselman Equities for the approval of a Final Plat for Lot 1, Block A, Texas Products Addition being a 6.68-acre tract of land identified as Tracts 21 & 21-01 of the D. Harr Survey, Abstract No. 102, City of Rockwall, Rockwall County, Texas, zoned Light Industrial (LI) District, situated within the Airport Overlay (AP-OV) District, addressed as 1775 Airport Road, and take any action necessary.
6. **P2024-039** - Consider a request by Matthew J. Peterson of DB Constructors, Inc. on behalf of Phil Wagner of the Rockwall Economic Development Corporation (REDC) for the approval of a Replat for Lot 4, Block B, Rockwall Technology Park, Phase 2 being a 10.65-acre parcel of land identified as Lot 2, Block B, Rockwall Technology Park, Phase 2, City of Rockwall, Rockwall County, Texas, zoned Light Industrial (LI) District, situated within the FM-549 Overlay (FM-549 OV) District, addressed as 2911 Corporate Crossing, and take any action necessary.
7. Consider authorizing the City Manager to execute a contract with Pipeline Analysis, LLC for the Sanitary Sewer Condition Assessment in the amount of \$176,406.00 to be funded by the Sewer Operations Budget, and take any action necessary.
8. Consider awarding a bid to United Turf & Track associated with athletic field renovations at

five locations in the amount of \$114,200 to be funded by the Recreation Development Fund, including authorizing the City Manager to execute related purchase orders and/or contracts, and take any action necessary.

9. Consider approval of a project budget in the amount of \$100,000 for repairs to Fire Station 2, authorizing the City Manager to execute an agreement with Custard Construction Services in the amount of \$78,078.76, amending the FY 2025 Internal Operations Department operating budget, and take any action necessary.
10. Consider approval of a recommendation from the Hotel Occupancy Tax (HOT) Subcommittee awarding \$50,000 in funding for AmeriSports, authorizing the City Manager to execute the associated agreements, and take any action necessary.

**X. City Manager's Report, Departmental Reports and Related Discussions Pertaining To Current City Activities, Upcoming Meetings, Future Legislative Activities, and Other Related Matters.**

1. Building Inspections Department Monthly Report
2. Fire Department Monthly Report
3. Parks & Recreation Department Monthly Report
4. Police Department Monthly Report
5. Sales Tax Historical Comparison
6. Water Consumption Historical Statistics

**XI. Adjournment**

This facility is wheelchair accessible and accessible parking spaces are available. Request for accommodations or interpretive services must be made 48 hours prior to this meeting. Please contact the City Secretary's Office at (972) 771-7700 or FAX (972) 771-7727 for further information.

The City of Rockwall City Council reserves the right to adjourn into executive session at any time to discuss any of the matters listed on the agenda above, as authorized by Texas Government Code ¶ 551.071 (Consultation with Attorney) ¶ 551.072 (Deliberations about Real Property) ¶ 551.074 (Personnel Matters) and ¶ 551.087 (Economic Development)

I, Kristy Teague, City Secretary for the City of Rockwall, Texas, do hereby certify that this Agenda was posted at City Hall, in a place readily accessible to the general public at all times, on the 27th day of November 2024 at 1 PM and remained so posted for at least 72 continuous hours preceding the scheduled time of said meeting.

---

Kristy Teague, City Secretary  
or Margaret Delaney, Asst. to the City Sect.

---

Date Removed



## **Life-Saving Award Officer Mitchell Attaway**

**On Friday, September 27<sup>th</sup>, 2024 at approximately 3:15pm, Officers responded to a residence on Bristlecone Court in reference to a family disturbance. The caller reported that their adult son was violently attacking her and her husband with a knife and that their son had cut her husband's neck. Upon arrival, Officers located the suspect and safely took him into custody. Simultaneously, the suspect's father had stumbled out onto the front driveway and was losing a large amount of blood from an injury on his neck. Officer Mitchell Attaway immediately began administering aid and calmly began reassuring the victim. Officer Attaway directed another officer to bring him a medical bag and a pressure dressing was applied and packed into the wound to slow the significant blood loss. EMS arrived several minutes later and transported the victim to an area hospital where he underwent emergency surgery to repair damage to his neck which included a laceration to a major vein.**

**A statement from Rockwall County EMS personnel indicated that Officer Attaway's quick intervention mitigated the victim's blood loss which contributed to saving the life of this victim. For his quick response to a direct threat to human life, Officer Attaway is hereby conferred the Life Saving Award.**

*Rockwall Police Department*  
**LIFE-SAVING AWARD**

PRESENTED TO



*Officer Mitchell Attaway*



*For his swift actions and being directly responsible for  
saving a human life on September 27, 2024*

*Presented on December 2, 2024*

A large, stylized handwritten signature in black ink, appearing to read "Edward Fowler".

*Chief Edward Fowler  
Chief of Police  
Rockwall Police Department*





---

## ROCKWALL CITY COUNCIL MEETING

**Monday, November 18, 2024 - 5:00 PM**

**City Hall Council Chambers - 385 S. Goliad St., Rockwall, TX 75087**

### **I. Call Public Meeting to Order**

Mayor Johannesen called the public meeting to order at 5:00 p.m. Present were Mayor Trace Johannesen, Mayor Pro Tem Clarence Jorif and Councilmembers Sedric Thomas, Mark Moeller, Anna Campbell, Dennis Lewis and Tim McCallum. Also present were City Manager Mary Smith and Assistant City Manager Joey Boyd. City Attorney Frank Garza was absent from the public portion of the meeting but did attend Executive Session remotely via video teleconference.

Mayor Johannesen read the below-listed discussion items into the record before recessing the public meeting to go into Executive Session at 5:01 p.m.

### **II. Executive Session**

1. Discussion regarding (re)appointments to city boards and commissions, pursuant to §551.074 (Personnel Matters).
2. Discussion regarding possible settlement re: City of Rockwall vs. Richard Brooks & Lake Pointe Health Science Center, pursuant to §551.071 (Consultation with Attorney).
3. Discussion regarding possible City Charter amendments and related legal advice, pursuant to §Section 551.071 (Consultation with Attorney).

### **III. Adjourn Executive Session**

Council concluded Executive Session at 5:30 p.m.

### **IV. Reconvene Public Meeting (6:00 P.M.)**

Mayor Johannesen reconvened the public meeting at 6:00 p.m.

### **V. Invocation and Pledge of Allegiance - Mayor Johannesen**

Mayor Johannesen delivered the invocation and led the Pledge of Allegiance.

### **VI. Appointment Items**

1. Appointment with Planning & Zoning Commission representative to discuss and answer any questions regarding planning-related cases on the agenda.

**P&Z Chairman, Derek Deckard, came forth and briefed Council on recommendations of the Commission regarding planning-related items on the agenda. Council took no formal action as a result of his briefing.**

## VII. Open Forum

No one came forth to speak during Open Forum.

## VIII. Take Any Action as a Result of Executive Session

Mayor Pro Tem Jorif moved to approve the settlement regarding the City of Rockwall v. Dr. Richard Brooks Estate lawsuit for the City to receive \$332,500, authorizing the City Manager to execute all necessary documents to finalize the settlement. Councilmember Thomas seconded the motion, which passed unanimously of those present (7 ayes to 0 nays).

Councilmember McCallum moved to appoint Stan Jeffus to serve on the city's Charter Review Commission. Councilmember Thomas seconded the motion, which passed by a vote of 7 ayes to 0 nays.

Mayor Johannesen moved to reappoint the following individuals to serve an additional two-year term on the Rockwall Economic Development Corporation (REDC) Board of Directors (term to expire December of 2026): Carin Brock, Justin Lee, Eric Burress and Darren Shue. Councilmember McCallum seconded the motion, which passed unanimously of those present (7 ayes to 0 nays).

## IX. Consent Agenda

1. Consider approval of the minutes from the November 4, 2024 city council meeting, and take any action necessary.
2. Consider approval of a recommendation from the Hotel Occupancy Tax (HOT) Subcommittee awarding funding for the Children's Advocacy Center in the amount of \$30,000, and the Rockwall Summer Musicals in the amount of \$10,000 authorizing the City Manager to execute the associated agreements, and take any action necessary.
3. Consider authorizing the City Manager to execute a one-year contract with Evoqua Water Technologies for chemical injections for \$90,000 annually to be funded by the Wastewater Operations Budget, and take any action necessary.
4. Consider approval of the material testing contract for Little Buffalo Wastewater System Extension and authorize the City Manager to execute a construction contract with Henley Johnston & Associates in the amount of \$19,050 to be funded by the State and Local Fiscal Recovery Funds, and take any action necessary.
5. Consider approval of the contract for the purchase and installation of video surveillance equipment for the City of Rockwall's water facilities and authorize the City Manager to execute a contract with Enterprise Security Solutions of Texas, Inc., in the amount of \$282,802.46, to be funded by the State and Local Fiscal Recovery Funds, and take any action necessary.

Councilmember McCallum moved to approve the entire Consent Agenda (#s 1, 2, 3, 4 and 5). Councilmember Thomas seconded the motion, which passed by a vote of 7 ayes to 0 nays.

## X. Public Hearing Items

1. **Z2024-049** - Hold a public hearing to discuss and consider a request by Renee Ward, PE of Weir & Associates, Inc. on behalf of Conor Keilty, AIA of Structured REA-Rockwall Land, LLC for the approval of an ordinance for a Specific Use Permit (SUP) for a *Residence Hotel* on a 2.819-acre portion of a larger 4.767-acre parcel of land identified as Lot 6, Block B, Fit Sport Life Addition, City

of Rockwall, Rockwall County, Texas, zoned Commercial (C) District, situated within the FM-549 Overlay (FM-549 OV) District, generally located east of the intersection of FM-549 and Fit Sport Life Boulevard, and take any action necessary **(1st Reading)**.

Planning Director Ryan Miller provided background information regarding this agenda item. The subject property has remained vacant since its annexation into the City of Rockwall in July of 1997. On June 17, 2024, the City Council denied a Specific Use Permit (SUP) for a Residence Hotel [Case No. Z2024-023] without prejudice to allow the applicant to resubmit the request after the developer increased the parking area on the Amerisports property. On October 7, 2024, a building permit [Case No. COM2024-4701] was approved allowing an additional 101 parking spaces on the Amerisports property. This parking lot is currently under construction. The applicant has submitted a concept plan for a Residence Hotel (see Figure 1). According to the concept plan, the proposed hotel will consist of a four (4) story building with a 61,496 SF building footprint and a total of 107 guest rooms. The first floor will consist of 16,586 SF, and the second, third, and fourth floors will consist of 14,970 SF each. The total proposed square footage of all the floors is 61,496 SF. In addition to the Residence Hotel, the concept plan (see Figure 1) also shows the location of the pool, parking areas, and a pet area. The proposed facility will have access off of Fit Sport Life Boulevard and a cross access easement from the western and eastern properties (i.e. the future 7/11 Gas Station and the AmeriSports Facility). In this case, the proposed Residence Hotel will incorporate kitchen facilities, be fully furnished, and have internal corridors leading to the doorways for each unit. According to the Permissible Use Charts contained in Article 04, Permissible Uses, of the Unified Development Code (UDC), a Residence Hotel requires a Specific Use Permit (SUP) in a Commercial (C) District. In addition, according to the UDC, the maximum height for a building in a Commercial (C) District is 60-feet; however, the building height may be increased up to 240 feet if approved through a Specific Use Permit (SUP). In this case, the applicant is requesting a height of 65-feet. Mr. Miller indicated the provided concept plan currently conforms to the parking requirements for a Residence Hotel. Specifically, Article 06, Parking and Loading, of the Unified Development Code (UDC) requires that a Hotel provide one (1) parking space per each unit and 50.00% of the accessory uses provided in the Hotel. Based on the provided concept plan, the required parking for the proposed Residence Hotel is 125 parking spaces. Currently, the concept plan shows the provision of 144 parking spaces or 12 parking spaces over the requirement. Staff also pointed out that the concept plan shows that they will be removing 12 spaces from the adjacent property sports complex (i.e. AmeriSports), and has indicated to staff that these will be provided through the additional parking being added to the sports complex. If the Residence Hotel is constructed prior to the construction of the 101 parking spaces on the adjacent property (i.e. Amerisports), this will require the applicant to setup a parking agreement to utilize the 12 excess parking spaces on the proposed hotel property. This can be accomplished through the final plat process for this property in accordance with the requirements of the Unified Development Code (UDC); however, it is anticipated that the additional parking for the sports complex will be complete prior to the construction of the hotel.

On October 19, 2024, staff mailed 10 notices to property owners and occupants within 500-feet of the subject property. There are no Homeowner's Associations (HOA's)/Neighborhood Associations within 1,500-feet of the subject property participating in the Neighborhood Notification Program. At the time this report was drafted, staff had not received any responses in favor or opposition of the applicant's request. Approval of an SUP is a discretionary decision on the part of Council. The City's Planning & Zoning Commission has recommended approval of this request by a vote of 4-1, with Commissioner Hagaman dissenting and Commissioners Womble and Hustings being absent.

Mayor Johannesen asked for some clarification. Mr. Miller shared that any hotel in a commercial district requires a specific use permit. This hotel is somewhat in between a residence and limited service hotel. The reason it's being put forth as a 'residence' one is because of the kitchen facilities and food preparation area, which are very specific to the 'residence' related definition (and not included in the definition of a 'limited



service hotel).

Mayor Johannesen then opened the public hearing and called forth the applicant.

Renee Ward  
Weir & Associates  
2201 E. Lamar Boulevard  
Arlington, TX

Ms. Ward shared that her company the engineering firm on the project, and she is happy to answer any questions.

There being no questions of Ms. Ward and no members of the public indicating a desire to speak, Mayor Johannesen then closed the public hearing.

Councilmember Lewis asked what the anticipated completion timing is for the parking lot (the additional 101 spaces at AmeriSports). Tom Kelty, co-owner of the project who state he lives in Livingston, TX, came forth and shared that they are slated to pour concrete this Friday, and the parking lot is expected to be completed sometime in January. By June of 2025, they hope to be submitting for building permits. Mr. Miller shared that they still have additional processes (site plan, engineering and final platting) to go through prior to applying for / obtaining building permits for the hotel.

Pen Collins  
Gatehouse Capital (co-developer and the hotel partner)  
5603 Matalae Avenue  
Dallas, TX

Councilmember Thomas asked why this is being put forth as an 'extended stay.' Mr. Collins shared that the expected stay will likely be 2.7 and 3.5 days is the average expected length of stay. So they're not excessively long timeframes, and no discounts are given for longer stays. The other option was a "Hampton Inn," but essentially they did not find this most desirable for several reasons. A "Home 2" seemed to be the best option, all things considered. He shared that for someone to stay an entire month would cost roughly \$3,900, so it is not anticipated that many will do so.

Councilmember Thomas moved to approve Z2024-049, with the stipulation that the parking be completed prior to the building / construction beginning on the hotel. Councilmember Lewis concurred he would like to see the 101 parking spaces by AmeriSports be complete prior to building permits being issued. Planning Director, Ryan Miller, generally shared that this sort of stipulation really cannot be made, as zoning cannot have certain conditions placed on it.

Councilmember Thomas then amended his initial motion to approve Z2024-049, with the requirement that the parking spaces (12 spaces) being removed from AmeriSports be added back. Councilmember Moeller seconded the motion and briefly commented. The ordinance caption was read as follows:

**CITY OF ROCKWALL  
ORDINANCE NO. 24-XX  
SPECIFIC USE PERMIT NO. S-3XX**

**AN ORDINANCE OF THE CITY COUNCIL OF THE CITY OF ROCKWALL, TEXAS,  
AMENDING THE UNIFIED DEVELOPMENT CODE (UDC) [*ORDINANCE NO. 20-02*] OF  
THE CITY OF ROCKWALL, ROCKWALL COUNTY, TEXAS, AS PREVIOUSLY**

AMENDED, SO AS TO GRANT A SPECIFIC USE PERMIT (SUP) FOR A *RESIDENCE HOTEL* ON A 2.819-ACRE PORTION OF A LARGER 4.767-ACRE PARCEL OF LAND IDENTIFIED AS LOT 6, BLOCK B, FIT SPORT LIFE ADDITION, CITY OF ROCKWALL, ROCKWALL COUNTY, TEXAS; AND MORE SPECIFICALLY DESCRIBED AND DEPICTED IN *EXHIBITS 'A' AND 'B'* OF THIS ORDINANCE; PROVIDING FOR SPECIAL CONDITIONS; PROVIDING FOR A PENALTY OF FINE NOT TO EXCEED THE SUM OF TWO THOUSAND DOLLARS (\$2,000.00) FOR EACH OFFENSE; PROVIDING FOR A SEVERABILITY CLAUSE; PROVIDING FOR A REPEALER CLAUSE; PROVIDING FOR AN EFFECTIVE DATE.

The motion to approve passed by a vote of 7 ayes to 0 nays.

2. **Z2024-050** - Hold a public hearing to discuss and consider a request by Jim Joyce on behalf of JFI Series 1, LLC for the approval of an **ordinance** for a *Specific Use Permit (SUP)* for *Residential Infill Adjacent to an Established Subdivision* on a 0.1340-acre parcel of land identified as Lot 5A-R of the Lofland Addition, City of Rockwall, Rockwall County, Texas, zoned Two-Family (2F) District, generally located on the west side of Bost Street north of the intersection of St. Mary's Street and Bost Street, and take any action necessary (**1st Reading**).

Planning Director Ryan Miller provided background information regarding this agenda item. The applicant is requesting the approval of a Specific Use Permit (SUP) for the purpose of constructing a duplex on the subject property. The structure is proposed to be a two-story, 3,446 SF residence. Council is being asked to look at and evaluate the proposed location, size and architecture of the proposed duplex when compared to other, existing nearby residences. With the exception of the proposed garage orientation and the city's anti-monotony standards, the proposed duplex does meet city requirements. Staff mailed out 120 notices to property owners and occupants located within 500' of the subject property. Also, nearby HOAs participating in the Neighborhood Notification Program were also given notice. Staff has not received any replies as a result of those notices. The Planning & Zoning Commission has recommended approval of this item by a vote of 5 to 0.

Mayor Johannesen opened the public hearing, asking if the applicant or anyone would like to come forth and speak. There being no one indicating such, he then closed the public hearing.

Councilmember Lewis moved to approve Z2024-050. Councilmember Campbell seconded the motion, and the ordinance caption was read as follows:

CITY OF ROCKWALL  
ORDINANCE NO. 24-XX  
SPECIFIC USE PERMIT NO. S-3XX

AN ORDINANCE OF THE CITY COUNCIL OF THE CITY OF ROCKWALL, TEXAS, AMENDING THE UNIFIED DEVELOPMENT CODE (UDC) [*ORDINANCE NO. 20-02*] OF THE CITY OF ROCKWALL, ROCKWALL COUNTY, TEXAS, AS PREVIOUSLY AMENDED, SO AS TO GRANT A SPECIFIC USE PERMIT (SUP) FOR *RESIDENTIAL INFILL ADJACENT TO AN ESTABLISHED SUBDIVISION* TO ALLOW THE CONSTRUCTION OF A DUPLEX ON A 0.1340-ACRE PARCEL OF LAND, IDENTIFIED AS LOT 5A-R OF THE LOFLAND ADDITION, CITY OF ROCKWALL, ROCKWALL COUNTY, TEXAS; AND MORE SPECIFICALLY DESCRIBED AND DEPICTED IN *EXHIBIT 'A'* OF THIS ORDINANCE; PROVIDING FOR SPECIAL CONDITIONS; PROVIDING FOR A PENALTY OF FINE NOT TO EXCEED THE SUM OF TWO THOUSAND DOLLARS (\$2,000.00) FOR EACH OFFENSE; PROVIDING FOR A SEVERABILITY CLAUSE; PROVIDING FOR A REPEALER CLAUSE; PROVIDING

**FOR AN EFFECTIVE DATE.**

**The motion to approve passed by a vote of 7 ayes to 0 nays.**

3. **Z2024-051** - Hold a public hearing to discuss and consider a request by Jim Joyce on behalf of JFI Series 1, LLC for the approval of an **ordinance** for a Specific Use Permit (SUP) for *Residential Infill Adjacent to an Established Subdivision* on a 0.1340-acre parcel of land identified as Lot 6A-R of the Lofland Addition, City of Rockwall, Rockwall County, Texas, zoned Two-Family (2F) District, generally located on the west side of Bost Street north of the intersection of St. Mary's Street and Bost Street, and take any action necessary (**1st Reading**).

**Planning Director Ryan Miller provided background information regarding this agenda item. He indicated that this request is almost entirely identical to the request above, and it is located 50' directly south of the previous property / previous agenda item. As was with the previous case, it does not totally meet the city's garage standards or anti monotony standards. Staff mailed out 124 notices to adjacent property owners and occupants, but not notices were received back. The Planning & Zoning Commission has recommended approval of this item by a vote of 5 to 0.**

**Mayor Johannesen opened the public hearing, asking if the applicant or anyone would like to come forth and speak. There being no one indicating such, he then closed the public hearing.**

**Councilmember Lewis moved to approve Z2024-051. Councilmember Thomas seconded the motion, and the ordinance caption was read as follows:**

**CITY OF ROCKWALL  
ORDINANCE NO. 24-XX  
SPECIFIC USE PERMIT NO. S-3XX**

**AN ORDINANCE OF THE CITY COUNCIL OF THE CITY OF ROCKWALL, TEXAS, AMENDING THE UNIFIED DEVELOPMENT CODE (UDC) [*ORDINANCE NO. 20-02*] OF THE CITY OF ROCKWALL, ROCKWALL COUNTY, TEXAS, AS PREVIOUSLY AMENDED, SO AS TO GRANT A SPECIFIC USE PERMIT (SUP) FOR *RESIDENTIAL INFILL ADJACENT TO AN ESTABLISHED SUBDIVISION* TO ALLOW THE CONSTRUCTION OF A DUPLEX ON A 0.1340-ACRE PARCEL OF LAND, IDENTIFIED AS LOT 6A-R OF THE LOFLAND ADDITION, CITY OF ROCKWALL, ROCKWALL COUNTY, TEXAS; AND MORE SPECIFICALLY DESCRIBED AND DEPICTED IN *EXHIBIT 'A'* OF THIS ORDINANCE; PROVIDING FOR SPECIAL CONDITIONS; PROVIDING FOR A PENALTY OF FINE NOT TO EXCEED THE SUM OF TWO THOUSAND DOLLARS (\$2,000.00) FOR EACH OFFENSE; PROVIDING FOR A SEVERABILITY CLAUSE; PROVIDING FOR A REPEALER CLAUSE; PROVIDING FOR AN EFFECTIVE DATE.**

**The motion to approve passed by a vote of 7 ayes to 0 nays.**

4. **Z2024-052** - Hold a public hearing to discuss and consider a request by Chad and Cindy Shirley for the approval of an **ordinance** for a Specific Use Permit (SUP) for a *Private Sports Court with Standalone or Dedicated Lighting* on a 0.3444-acre parcel of land identified as Lot 6, Block 2, Gideon Grove Addition, City of Rockwall, Rockwall County, Texas, zoned Planned Development District 77 (PD-77) for Single-Family 10 (SF-10) District land uses, addressed as 1313 Gideon Way, and take any action necessary (**1st Reading**).

**Planning Director Ryan Miller provided background information regarding this agenda item. Any potential approval of this request will require a super majority vote of Council. The address of the location is 1313**

Gideon Way, and the applicant is requesting the approval of a Specific Use Permit (SUP) to allow the construction of a Private Sports Court with Dedicated or Standalone Lighting. The applicant has submitted an application, concept plan, and photometric plan proposing to construct a 45' 2" X 28' 6" (or 1287.25 SF) Private Sports Court with Standalone or Dedicated Lighting on the subject property. The proposed structure will be situated on a concrete pad. The applicant has also indicated that there will be four (4), 14-foot light poles with a LED Shoebox Area Light mounted to each pole. Each of the light standards will be directed downward toward the middle of the Sports Court; however, the applicant's submitted materials do not show that the lights will be shielded. On October 19, 2024, staff mailed 64 notices to property owners and occupants within 500-feet of the subject property. Staff also sent a notice to the Stoney Hollow Homeowner's Association (HOA), which is the only HOA's or Neighborhood Organizations within 1,500-feet of the subject property participating in the Neighborhood Notification Program. Additionally, staff posted a sign on the subject property, and advertised the public hearings in the Rockwall Herald Banner as required by the Unified Development Code (UDC). At the time this report was drafted, staff has received four (4) notices back in opposition of the applicant's request. In addition, on November 12, 2024, the Planning and Zoning Commission approved a motion to recommend denial of the Specific Use Permit (SUP) by a vote of 5-0, with commissioners Womble and Hustings absent.

Following Mr. Miller's briefing, Mayor Johannesen opened the public hearing, but with no one indicating a desire to come forth and speak, he then closed the public hearing.

Councilmember Thomas briefly commented he knows several neighbors have opposition to this request, specifically because of the lighting and that it will not be shielded. Also, the HOA did not approve this. For these reasons, Councilmember Thomas then made a motion to deny Z2024-052. Councilmember Lewis seconded the motion. Mayor Pro Tem Jorif shared that he knows the applicants and will, therefore, be abstaining from the vote. The motion to deny the item then passed by a vote of 6 ayes with 1 abstention (Jorif).

#### XI. Adjournment

Mrs. Smith, City Manager, briefly reminded Council of the "State of the City" prestaton slated for this Wednesday at the monthly Chamber of Commerce lunch. She shared that a "Notice of a Quorum" was posted, as city business will be discussed, and – even though no action is anticipated – all seven councilmembers have indicated they plan to attend. So, it was appropriate to post this notice.

Mayor Johannesen adjourned the meeting at 6:31 p.m.

PASSED AND APPROVED BY THE CITY COUNCIL OF THE CITY OF ROCKWALL, TEXAS ON THIS 2<sup>nd</sup> DAY OF DECEMBER, 2024.

---

Trace Johannesen, Mayor

ATTEST:

---

Kristy Teague, City Secretary

CITY OF ROCKWALL

ORDINANCE NO. 24-48

SPECIFIC USE PERMIT NO. S-348

AN ORDINANCE OF THE CITY COUNCIL OF THE CITY OF ROCKWALL, TEXAS, AMENDING THE UNIFIED DEVELOPMENT CODE (UDC) [ORDINANCE NO. 20-02] OF THE CITY OF ROCKWALL, ROCKWALL COUNTY, TEXAS, AS PREVIOUSLY AMENDED, SO AS TO GRANT A SPECIFIC USE PERMIT (SUP) FOR A *RESIDENCE HOTEL* ON A 2.819-ACRE PORTION OF A LARGER 4.767-ACRE PARCEL OF LAND IDENTIFIED AS LOT 6, BLOCK B, FIT SPORT LIFE ADDITION, CITY OF ROCKWALL, ROCKWALL COUNTY, TEXAS; AND MORE SPECIFICALLY DESCRIBED AND DEPICTED IN *EXHIBITS 'A' AND 'B'* OF THIS ORDINANCE; PROVIDING FOR SPECIAL CONDITIONS; PROVIDING FOR A PENALTY OF FINE NOT TO EXCEED THE SUM OF TWO THOUSAND DOLLARS (\$2,000.00) FOR EACH OFFENSE; PROVIDING FOR A SEVERABILITY CLAUSE; PROVIDING FOR A REPEALER CLAUSE; PROVIDING FOR AN EFFECTIVE DATE.

**WHEREAS**, the City has received a request from Renee Ward, PE of Weir & Associates, Inc. on behalf of Conor Keilty, AIA of Structured REA-Rockwall Land, LLC for the approval of a *Specific Use Permit (SUP)* for a *Residence Hotel* on a 2.819-acre portion of a larger 4.767-acre parcel of land identified as Lot 6, Block B, Fit Sport Life Addition, City of Rockwall, Rockwall County, Texas, zoned Commercial (C) District, situated within the FM-549 Overlay (FM-549 OV) District, generally located east of the intersection of FM-549 and Fit Sport Life Boulevard, and being more specifically described and depicted in *Exhibits 'A' and 'B'* of this ordinance, which herein after shall be referred to as the *Subject Property* and incorporated by reference herein; and

**WHEREAS**, the Planning and Zoning Commission of the City of Rockwall and the governing body of the City of Rockwall, in compliance with the laws of the State of Texas and the ordinances of the City of Rockwall, have given the requisite notices by publication and otherwise, and have held public hearings and afforded a full and fair hearing to all property owners generally, and to all persons interested in and situated in the affected area and in the vicinity thereof, the governing body in the exercise of its legislative discretion has concluded that Unified Development Code (UDC) [Ordinance No. 20-02] of the City of Rockwall should be amended as follows:

**NOW, THEREFORE, BE IT ORDAINED** by the City Council of the City of Rockwall, Texas;

**SECTION 1.** That the Unified Development Code (UDC) [Ordinance No. 20-02] of the City of Rockwall, as heretofore amended, be and the same is hereby amended so as to grant a Specific Use Permit (SUP) for a *Residence Hotel* as stipulated by Subsection 01.02, *Land Use Schedule*, of Article 04, *Permissible Uses*, of the Unified Development Code (UDC) [Ordinance No. 20-02] on the *Subject Property*; and,

**SECTION 2.** That the Specific Use Permit (SUP) shall be subject to the requirements set forth in Subsection 04.01, *General Commercial District Standards*; Subsection 04.05, *Commercial (C) District*; Subsection 06.02, *General Overlay District Standards*; and, Subsection 06.13, *FM-549 Overlay District*, of Article 05, *District Development Standards*, of the Unified Development Code

(UDC) [Ordinance No. 20-02] -- as heretofore amended and as may be amended in the future --, and with the following conditions:

## 2.1. OPERATIONAL CONDITIONS

The following conditions pertain to the operation of a *Residence Hotel* on the *Subject Property* and conformance to these conditions are required for continued operations:

- (1) The development of this property shall generally conform to the *Concept Plan* depicted in *Exhibit 'B'* of this Specific Use Permit (SUP) ordinance for the development of a *Residence Hotel*.
- (2) The development of the subject property shall generally conform to the *Building Elevations* depicted in *Exhibit 'C'* of this ordinance; however, these elevations shall be subject to the *General Overlay District Standards* as stipulated by Article 05, *District Development Standards*, of the Unified Development Code (UDC) and review and recommendation by the Architecture Review Board (ARB) prior to approval by the Planning and Zoning Commission at the time of site plan. In addition, the approval of this Specific Use Permit (SUP) shall not constitute the approval of a variance or exception to any of the standards stipulated by the Unified Development Code (UDC) with regard to the design of the *Residence Hotel*.
- (3) The maximum overall height of the building shall not exceed four (4)-stories or 60-feet.

## 2.2. COMPLIANCE

Approval of this ordinance in accordance with Subsection 02.02, *Specific Use Permits (SUP)*, of Article 11, *Development Applications and Review Procedures*, of the Unified Development Code (UDC) will require compliance to the following:

- (1) Upon obtaining a *Certificate of Occupancy (CO)* and/or building permit, should the business owner operating under the guidelines of this ordinance fail to meet the minimum operational requirements set forth herein and outlined in the Unified Development Code (UDC), the City may (*after proper notice*) initiate proceedings to revoke the Specific Use Permit (SUP) in accordance with Subsection 02.02(F), *Revocation*, of Article 11, *Development Applications and Revision Procedures*, of the Unified Development Code (UDC) [Ordinance No. 20-02].

**SECTION 3.** That the official zoning map of the City be corrected to reflect the changes in zoning described herein.

**SECTION 4.** That all ordinances of the City of Rockwall in conflict with the provisions of this ordinance be, and the same are hereby repealed to the extent of that conflict.

**SECTION 5.** Any person, firm, or corporation violating any of the provisions of this ordinance shall be deemed guilty of a misdemeanor and upon conviction shall be punished by a penalty of fine not to exceed the sum of *TWO THOUSAND DOLLARS (\$2,000.00)* for each offence and each and every day such offense shall continue shall be deemed to constitute a separate offense.

**SECTION 6.** If any section or provision of this ordinance or the application of that section or provision to any person, firm, corporation, situation or circumstance is for any reason judged invalid, the adjudication shall not affect any other section or provision of this ordinance or the

application of any other section or provision to any other person, firm, corporation, situation or circumstance, and the City Council declares that it would have adopted the valid portions and applications of the ordinance without the invalid parts and to this end the provisions of this ordinance shall remain in full force and effect.

**SECTION 7.** That this ordinance shall take effect immediately from and after its passage.

**PASSED AND APPROVED BY THE CITY COUNCIL OF THE CITY OF ROCKWALL, TEXAS, THIS THE 2<sup>ND</sup> DAY OF DECEMBER, 2024.**

\_\_\_\_\_  
Trace Johannesen, Mayor

**ATTEST:**

\_\_\_\_\_  
Kristy Teague, City Secretary

**APPROVED AS TO FORM:**

\_\_\_\_\_  
Frank J. Garza, City Attorney

1<sup>st</sup> Reading: November 18, 2024

2<sup>nd</sup> Reading: December 2, 2024

**Exhibit 'A'**  
*Legal Description*

*BEING* a tract of land located in the Robert Boyd Irvine Survey, Abstract No. 120, Rockwall County, Texas, being a portion of Lot 6, Block B, Fit Sport Life Addition, an addition to the City of Rockwall, Rockwall County, Texas according to the plat recorded in Instrument No. 20220000003843, official public records, Rockwall County, Texas (O.P.R.C.C.T.), and being more particularly described by metes and bounds as follows:

*BEGINNING* at a ½" iron rod with cap stamped "Wier & Assoc Inc", in the south right-of-way line of Fit Sport Life Boulevard (a 60' right-of-way), said iron rod being the northeast corner of said Lot 6 and the northwest corner of Lot 5, Block B of said Fit Sport Life Addition;

*THENCE* S 27°18'10" E, departing the south right-of-way line of said Fit Sport Life Boulevard, along the east line of said Lot 6 and the west line of said Lot 5, a distance of 471.23 feet to a ½" iron rod found with a cap stamped "Wier & Assoc Inc", in the north line of Lot 1, Block B, Rockwall Technology Park Phase IV, an addition to the City of Rockwall. Rockwall County, Texas according to the plat recorded in Instrument No. 20160000023061, O.P.R.R.C.T., said iron being the southeast corner of said Lot 6 and the southwest corner of said Lot 5.

*THENCE* S 89°10'38" W, along the south line of said Lot 6 and the north line of said Lot 1, a distance of 410.08 feet to a point;

*THENCE* N 00°36'39" W, departing the south line of said Lot 6 and the north line of said Lot 1, a distance of 149.65 feet to a point, being the beginning of a curve to the left;

*THENCE* Northwesterly, an arc length of 48.96 feet along said curve to the left, having a radius of 110.00 feet, a delta angle of 25°30'11", and a chord bearing N 13°21'44" W, a distance of 48.56 feet to a point;

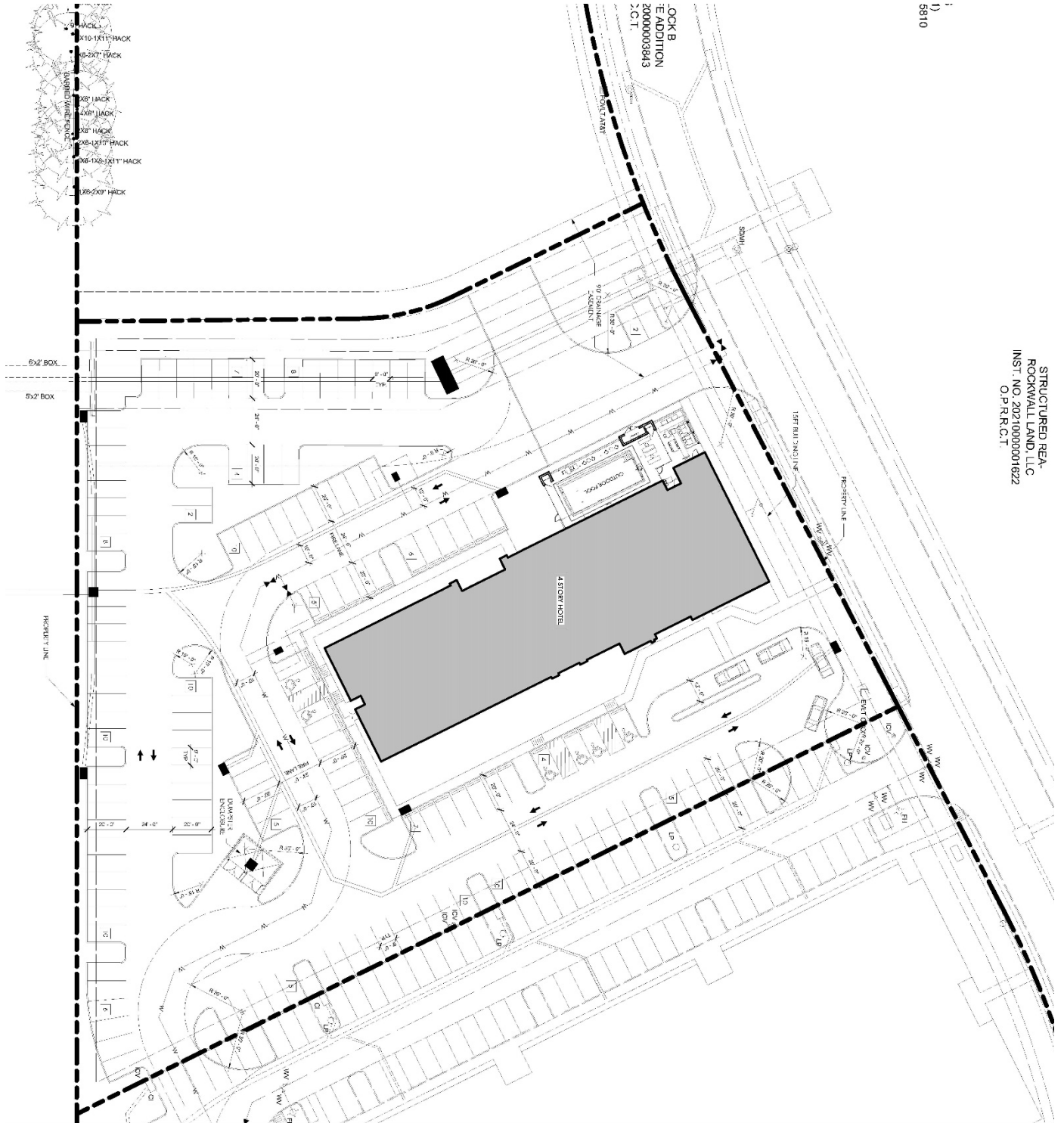
*THENCE* N 26°06'50" W, a distance of 109.76 feet to a point in the north line of said Lot 6 and in the south right-of-way line of said Fit Sport Life Boulevard, being the beginning of a non-tangent curve to the left;

*THENCE* Northeasterly, an arc length of 50.67 feet along the north line of said Lot 6, the south right-of-way line of said Fit Sport Life Boulevard, and said curve to the left, having a radius of 530.00 feet, a delta angle of 05°28'40", and a chord bearing of N 65°23'25" E, a distance of 50.65 feet to a ½" iron rod found with a cap stamped "Wier & Assoc Inc";

*THENCE* N 62°39'05" E, continuing along the north line of said Lot 6 and the south right-of-way line of said Fit Sport Life Boulevard, a distance of 235.27 feet to the place of beginning and containing 2.819 acres (122,785 square feet) of land, more or less.



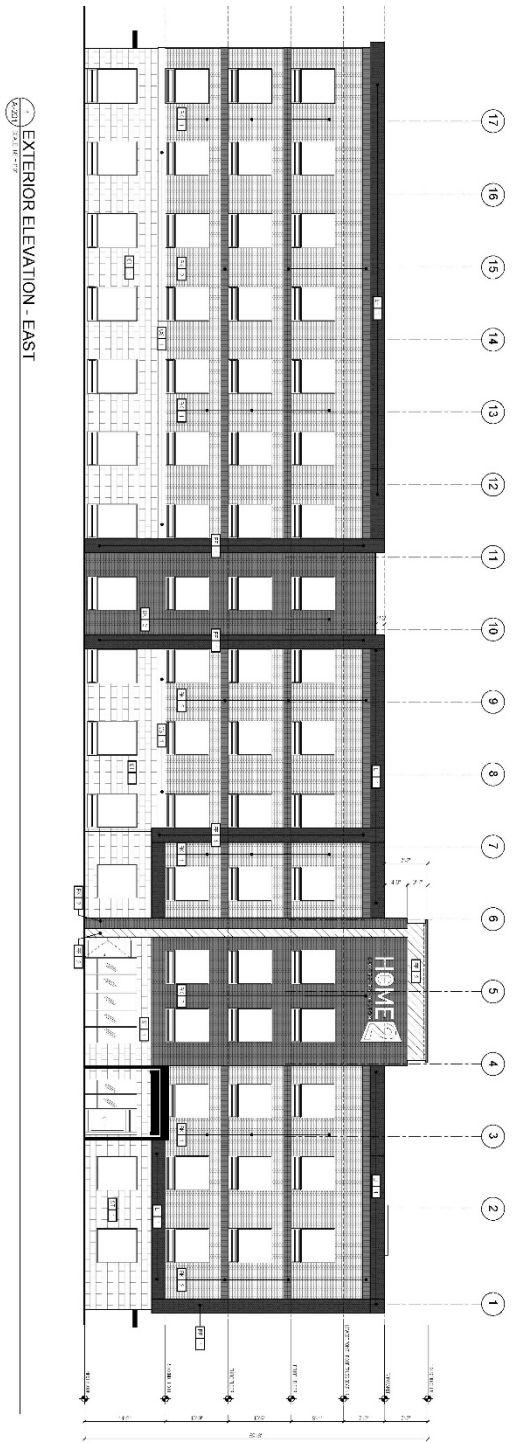
# Exhibit 'B' Concept Plan



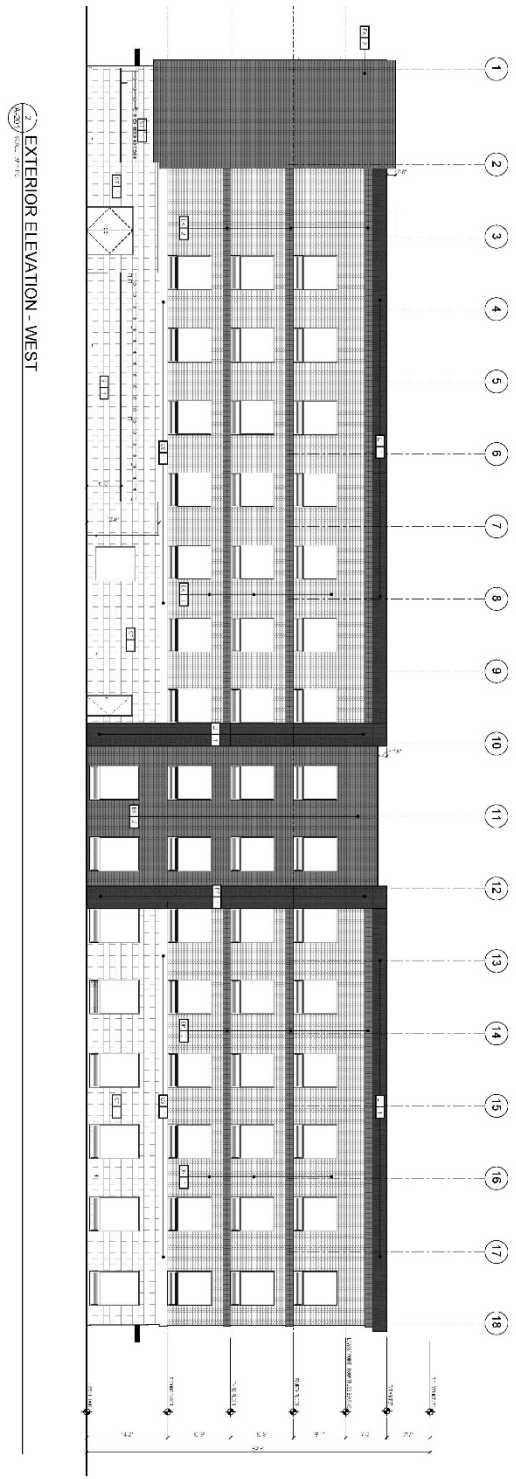
1)  
5810

STRUCTURED REA-  
ROCKWALL LAND, LLC  
INST. NO. 2021000001622  
O.P.R.R.C.T.

# Exhibit 'C': Building Elevations



EXTERIOR ELEVATION - EAST



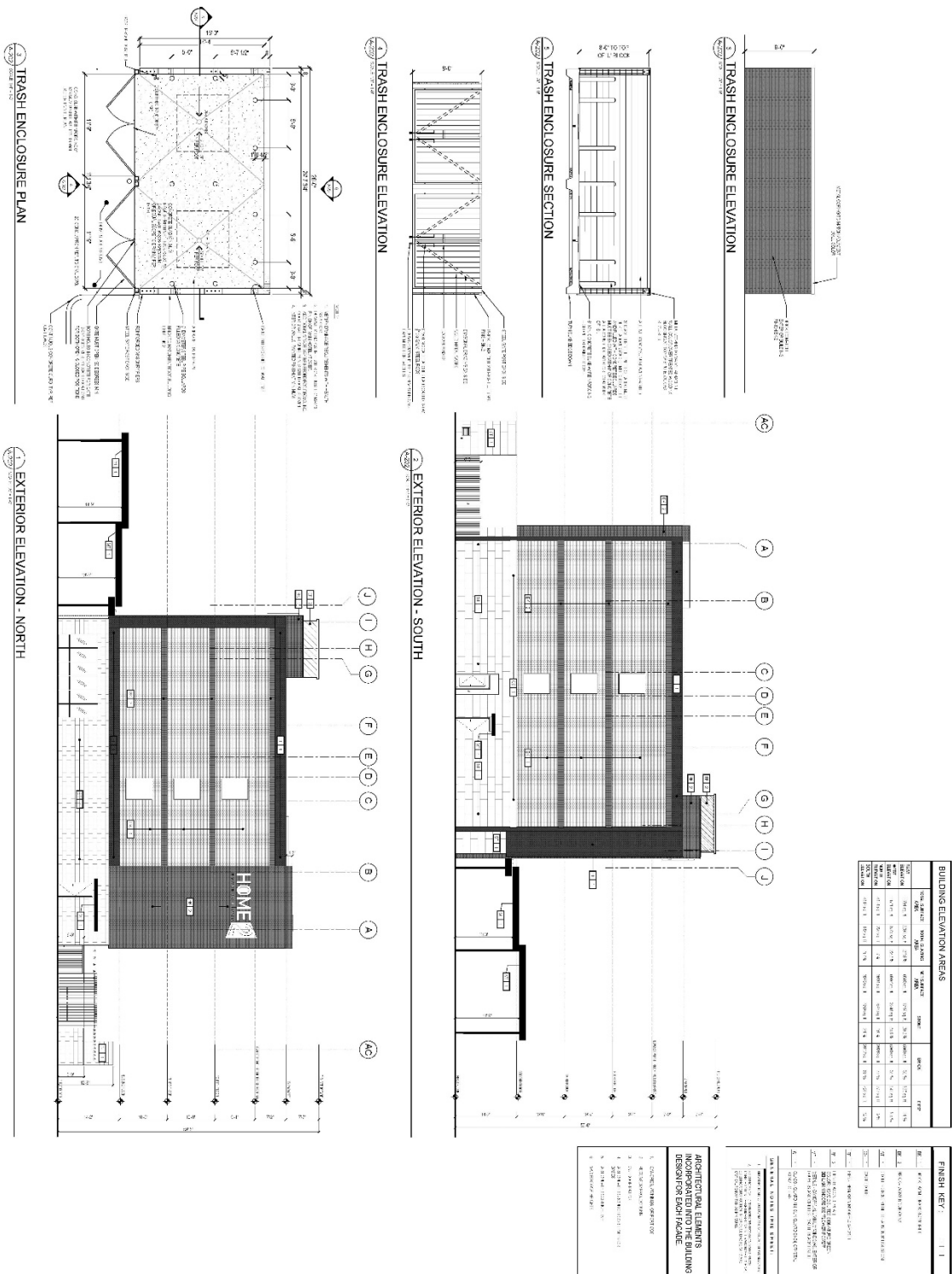
EXTERIOR ELEVATION - WEST

BUILDING ELEVATION AREAS									
GRID	GRID	GRID	GRID	GRID	GRID	GRID	GRID	GRID	GRID
1	2	3	4	5	6	7	8	9	10
1	2	3	4	5	6	7	8	9	10
11	12	13	14	15	16	17	18		

ARCHITECTURAL ELEMENTS	
1	ARCHITECTURAL ELEMENTS
2	ARCHITECTURAL ELEMENTS
3	ARCHITECTURAL ELEMENTS
4	ARCHITECTURAL ELEMENTS
5	ARCHITECTURAL ELEMENTS
6	ARCHITECTURAL ELEMENTS

FINISH KEY	
1	FINISH KEY
2	FINISH KEY
3	FINISH KEY
4	FINISH KEY
5	FINISH KEY
6	FINISH KEY

# Exhibit 'C': Building Elevations



CITY OF ROCKWALL

ORDINANCE NO. 24-49

SPECIFIC USE PERMIT NO. S-349

AN ORDINANCE OF THE CITY COUNCIL OF THE CITY OF ROCKWALL, TEXAS, AMENDING THE UNIFIED DEVELOPMENT CODE (UDC) [*ORDINANCE NO. 20-02*] OF THE CITY OF ROCKWALL, ROCKWALL COUNTY, TEXAS, AS PREVIOUSLY AMENDED, SO AS TO GRANT A SPECIFIC USE PERMIT (SUP) FOR *RESIDENTIAL INFILL ADJACENT TO AN ESTABLISHED SUBDIVISION* TO ALLOW THE CONSTRUCTION OF A DUPLEX ON A 0.1340-ACRE PARCEL OF LAND, IDENTIFIED AS LOT 5A-R OF THE LOFLAND ADDITION, CITY OF ROCKWALL, ROCKWALL COUNTY, TEXAS; AND MORE SPECIFICALLY DESCRIBED AND DEPICTED IN *EXHIBIT 'A'* OF THIS ORDINANCE; PROVIDING FOR SPECIAL CONDITIONS; PROVIDING FOR A PENALTY OF FINE NOT TO EXCEED THE SUM OF TWO THOUSAND DOLLARS (\$2,000.00) FOR EACH OFFENSE; PROVIDING FOR A SEVERABILITY CLAUSE; PROVIDING FOR A REPEALER CLAUSE; PROVIDING FOR AN EFFECTIVE DATE.

**WHEREAS**, the City has received a request by Jim Joyce for the approval of a *Specific Use Permit (SUP)* for *Residential Infill Adjacent to an Established Subdivision* for the purpose of constructing a duplex on a 0.1340-acre parcel of land identified as Lot 5A-R of the Lofland Addition, City of Rockwall, Rockwall County, Texas, zoned Two Family (2F) District land uses, generally located on the west side of Bost Street north of the intersection of St. Mary's Street and Bost Street, and being more specifically described and depicted in *Exhibit 'A'* of this ordinance, which herein after shall be referred to as the *Subject Property* and incorporated by reference herein; and

**WHEREAS**, the Planning and Zoning Commission of the City of Rockwall and the governing body of the City of Rockwall, in compliance with the laws of the State of Texas and the ordinances of the City of Rockwall, have given the requisite notices by publication and otherwise, and have held public hearings and afforded a full and fair hearing to all property owners generally, and to all persons interested in and situated in the affected area and in the vicinity thereof, the governing body in the exercise of its legislative discretion has concluded that the Unified Development Code (UDC) [*Ordinance No. 20-02*] of the City of Rockwall should be amended as follows:

**NOW, THEREFORE, BE IT ORDAINED** by the City Council of the City of Rockwall, Texas;

**SECTION 1.** That the Unified Development Code (UDC) [*Ordinance No. 20-02*] of the City of Rockwall, as heretofore amended, be and the same is hereby amended so as to grant a Specific Use Permit (SUP) for *Residential Infill Adjacent to an Established Subdivision* to allow for the construction of a duplex in an established subdivision in accordance with Article 04, *Permissible Uses*, of the Unified Development Code (UDC) [*Ordinance No. 20-02*] on the *Subject Property*; and,

**SECTION 2.** That the Specific Use Permit (SUP) shall be subject to the requirements set forth in Subsection 03.01, *General Residential District Standards*, and Subsection 03.11, *Two-Family (2F) District*, of Article 05, *District Development Standards*, of the Unified Development Code

(UDC) [Ordinance No. 20-02] -- as heretofore amended and may be amended in the future -- and with the following conditions:

## 2.1 OPERATIONAL CONDITIONS

The following conditions pertain to the construction of a duplex on the *Subject Property* and conformance to these operational conditions are required:

- 1) The development of the *Subject Property* shall generally conform to the Residential Plot Plan as depicted in *Exhibit 'B'* of this ordinance.
- 2) The construction of a duplex on the *Subject Property* shall generally conform to the Building Elevations depicted in *Exhibit 'C'* of this ordinance.
- 3) Once construction of the duplex has been completed, inspected, and accepted by the City of Rockwall, this Specific Use Permit (SUP) shall expire, and no further action by the property owner shall be required.

## 2.2 COMPLIANCE

Approval of this ordinance in accordance with Subsection 02.02, *Specific Use Permits (SUP)* of Article 11, *Development Applications and Review Procedures*, of the Unified Development Code (UDC) will require the *Subject Property* to comply with the following:

- 1) Upon obtaining a *Building Permit*, should the contractor operating under the guidelines of this ordinance fail to meet the minimum operational requirements set forth herein and outlined in the Unified Development Code (UDC), the City may (*after proper notice*) initiate proceedings to revoke the Specific Use Permit (SUP) in accordance with Subsection 02.02(F), *Revocation*, of Article 11, *Development Applications and Revision Procedures*, of the Unified Development Code (UDC) [Ordinance No. 20-02].

**SECTION 3.** That the official zoning map of the City be corrected to reflect the changes in zoning described herein.

**SECTION 4.** That all ordinances of the City of Rockwall in conflict with the provisions of this ordinance be, and the same are hereby repealed to the extent of that conflict.

**SECTION 5.** Any person, firm, or corporation violating any of the provisions of this ordinance shall be deemed guilty of a misdemeanor and upon conviction shall be punished by a penalty of fine not to exceed the sum of *TWO THOUSAND DOLLARS (\$2,000.00)* for each offence and each and every day such offense shall continue shall be deemed to constitute a separate offense.

**SECTION 6.** If any section or provision of this ordinance or the application of that section or provision to any person, firm, corporation, situation or circumstance is for any reason judged invalid, the adjudication shall not affect any other section or provision of this ordinance or the application of any other section or provision to any other person, firm, corporation, situation or circumstance, and the City Council declares that it would have adopted the valid portions and applications of the ordinance without the invalid parts and to this end the provisions of this ordinance shall remain in full force and effect.

**SECTION 7.** That this ordinance shall take effect immediately from and after its passage.

**PASSED AND APPROVED BY THE CITY COUNCIL OF THE CITY OF ROCKWALL, TEXAS,  
THIS THE 2<sup>ND</sup> DAY OF DECEMBER, 2024.**

\_\_\_\_\_  
Trace Johannesen, Mayor

**ATTEST:**

\_\_\_\_\_  
Kristy Teague, City Secretary

**APPROVED AS TO FORM:**

\_\_\_\_\_  
Frank J. Garza, City Attorney

1<sup>st</sup> Reading: November 18, 2024

2<sup>nd</sup> Reading: December 2, 2024

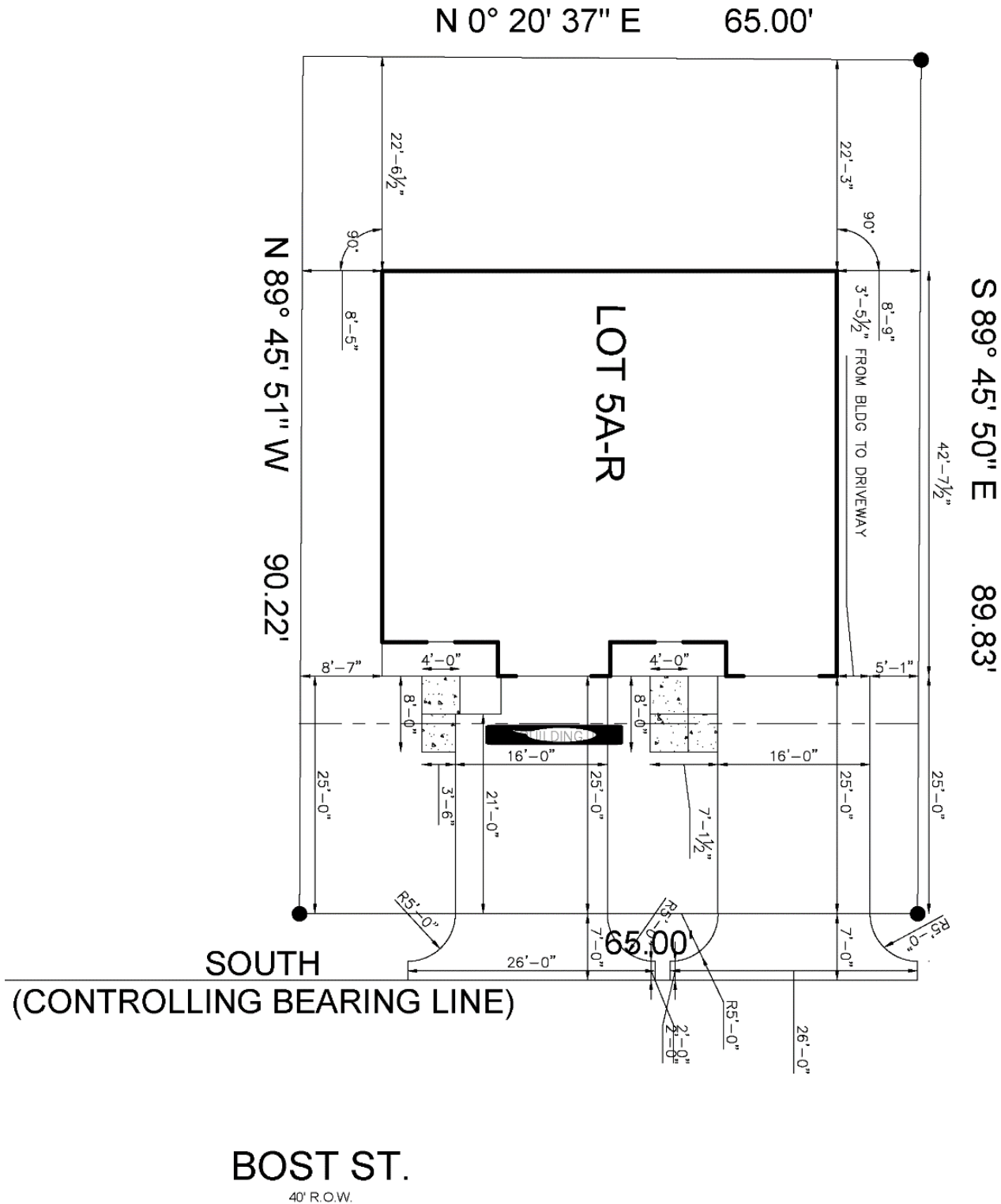
**Exhibit 'A':  
Location Map**

**Address:** West side of Bost Street and North of the intersection of St. Mary's Street and Bost Street

**Legal Description:** Lot 5A-R of the Lofland Addition

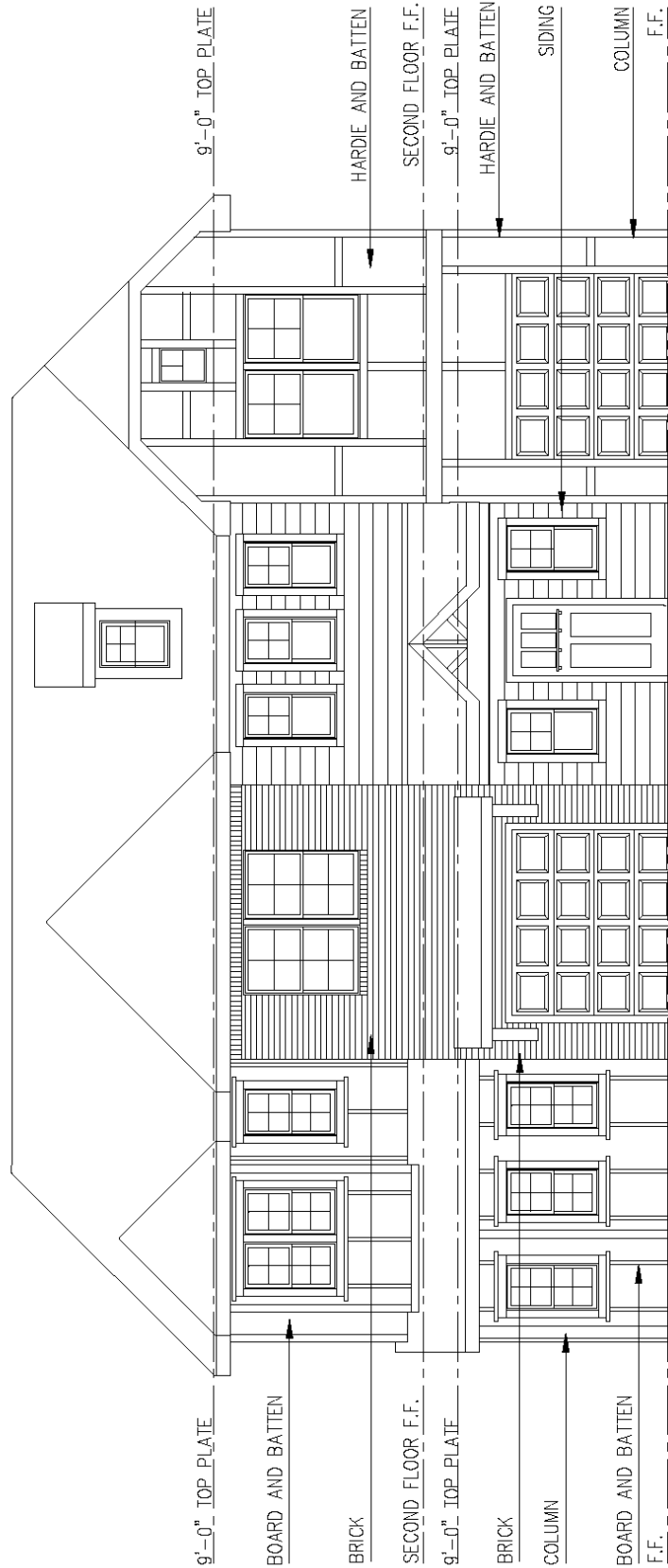


**Exhibit 'B':  
Residential Plot Plan**





**Exhibit 'C':**  
*Building Elevations*



**FRONT ELEVATION 5AR**

SCALE: 1/8" = 1'-0"

CITY OF ROCKWALL

ORDINANCE NO. 24-50

SPECIFIC USE PERMIT NO. S-350

AN ORDINANCE OF THE CITY COUNCIL OF THE CITY OF ROCKWALL, TEXAS, AMENDING THE UNIFIED DEVELOPMENT CODE (UDC) [*ORDINANCE NO. 20-02*] OF THE CITY OF ROCKWALL, ROCKWALL COUNTY, TEXAS, AS PREVIOUSLY AMENDED, SO AS TO GRANT A SPECIFIC USE PERMIT (SUP) FOR *RESIDENTIAL INFILL ADJACENT TO AN ESTABLISHED SUBDIVISION* TO ALLOW THE CONSTRUCTION OF A DUPLEX ON A 0.1340-ACRE PARCEL OF LAND, IDENTIFIED AS LOT 6A-R OF THE LOFLAND ADDITION, CITY OF ROCKWALL, ROCKWALL COUNTY, TEXAS; AND MORE SPECIFICALLY DESCRIBED AND DEPICTED IN *EXHIBIT 'A'* OF THIS ORDINANCE; PROVIDING FOR SPECIAL CONDITIONS; PROVIDING FOR A PENALTY OF FINE NOT TO EXCEED THE SUM OF TWO THOUSAND DOLLARS (\$2,000.00) FOR EACH OFFENSE; PROVIDING FOR A SEVERABILITY CLAUSE; PROVIDING FOR A REPEALER CLAUSE; PROVIDING FOR AN EFFECTIVE DATE.

**WHEREAS**, the City has received a request by Jim Joyce for the approval of a *Specific Use Permit (SUP)* for *Residential Infill Adjacent to an Established Subdivision* for the purpose of constructing a duplex on a 0.1340-acre parcel of land identified as Lot 6A-R of the Lofland Addition, City of Rockwall, Rockwall County, Texas, zoned Two Family (2F) District land uses, generally located on the west side of Bost Street north of the intersection of St. Mary's Street and Bost Street, and being more specifically described and depicted in *Exhibit 'A'* of this ordinance, which herein after shall be referred to as the *Subject Property* and incorporated by reference herein; and

**WHEREAS**, the Planning and Zoning Commission of the City of Rockwall and the governing body of the City of Rockwall, in compliance with the laws of the State of Texas and the ordinances of the City of Rockwall, have given the requisite notices by publication and otherwise, and have held public hearings and afforded a full and fair hearing to all property owners generally, and to all persons interested in and situated in the affected area and in the vicinity thereof, the governing body in the exercise of its legislative discretion has concluded that the Unified Development Code (UDC) [*Ordinance No. 20-02*] of the City of Rockwall should be amended as follows:

**NOW, THEREFORE, BE IT ORDAINED** by the City Council of the City of Rockwall, Texas;

**SECTION 1.** That the Unified Development Code (UDC) [*Ordinance No. 20-02*] of the City of Rockwall, as heretofore amended, be and the same is hereby amended so as to grant a Specific Use Permit (SUP) for *Residential Infill Adjacent to an Established Subdivision* to allow for the construction of a duplex in an established subdivision in accordance with Article 04, *Permissible Uses*, of the Unified Development Code (UDC) [*Ordinance No. 20-02*] on the *Subject Property*; and,

**SECTION 2.** That the Specific Use Permit (SUP) shall be subject to the requirements set forth in Subsection 03.01, *General Residential District Standards*, and Subsection 03.11, *Two-Family (2F) District*, of Article 05, *District Development Standards*, of the Unified Development Code

(UDC) [Ordinance No. 20-02] -- as heretofore amended and may be amended in the future -- and with the following conditions:

## 2.1 OPERATIONAL CONDITIONS

The following conditions pertain to the construction of a duplex on the *Subject Property* and conformance to these operational conditions are required:

- 1) The development of the *Subject Property* shall generally conform to the Residential Plot Plan as depicted in *Exhibit 'B'* of this ordinance.
- 2) The construction of a duplex on the *Subject Property* shall generally conform to the Building Elevations depicted in *Exhibit 'C'* of this ordinance.
- 3) Once construction of the duplex has been completed, inspected, and accepted by the City of Rockwall, this Specific Use Permit (SUP) shall expire, and no further action by the property owner shall be required.

## 2.2 COMPLIANCE

Approval of this ordinance in accordance with Subsection 02.02, *Specific Use Permits (SUP)* of Article 11, *Development Applications and Review Procedures*, of the Unified Development Code (UDC) will require the *Subject Property* to comply with the following:

- 1) Upon obtaining a *Building Permit*, should the contractor operating under the guidelines of this ordinance fail to meet the minimum operational requirements set forth herein and outlined in the Unified Development Code (UDC), the City may (*after proper notice*) initiate proceedings to revoke the Specific Use Permit (SUP) in accordance with Subsection 02.02(F), *Revocation*, of Article 11, *Development Applications and Revision Procedures*, of the Unified Development Code (UDC) [Ordinance No. 20-02].

**SECTION 3.** That the official zoning map of the City be corrected to reflect the changes in zoning described herein.

**SECTION 4.** That all ordinances of the City of Rockwall in conflict with the provisions of this ordinance be, and the same are hereby repealed to the extent of that conflict.

**SECTION 5.** Any person, firm, or corporation violating any of the provisions of this ordinance shall be deemed guilty of a misdemeanor and upon conviction shall be punished by a penalty of fine not to exceed the sum of *TWO THOUSAND DOLLARS (\$2,000.00)* for each offence and each and every day such offense shall continue shall be deemed to constitute a separate offense.

**SECTION 6.** If any section or provision of this ordinance or the application of that section or provision to any person, firm, corporation, situation or circumstance is for any reason judged invalid, the adjudication shall not affect any other section or provision of this ordinance or the application of any other section or provision to any other person, firm, corporation, situation or circumstance, and the City Council declares that it would have adopted the valid portions and applications of the ordinance without the invalid parts and to this end the provisions of this ordinance shall remain in full force and effect.

**SECTION 7.** That this ordinance shall take effect immediately from and after its passage.

**PASSED AND APPROVED BY THE CITY COUNCIL OF THE CITY OF ROCKWALL, TEXAS,  
THIS THE 2<sup>ND</sup> DAY OF DECEMBER, 2024.**

\_\_\_\_\_  
Trace Johannesen, Mayor

**ATTEST:**

\_\_\_\_\_  
Kristy Teague, City Secretary

**APPROVED AS TO FORM:**

\_\_\_\_\_  
Frank J. Garza, City Attorney

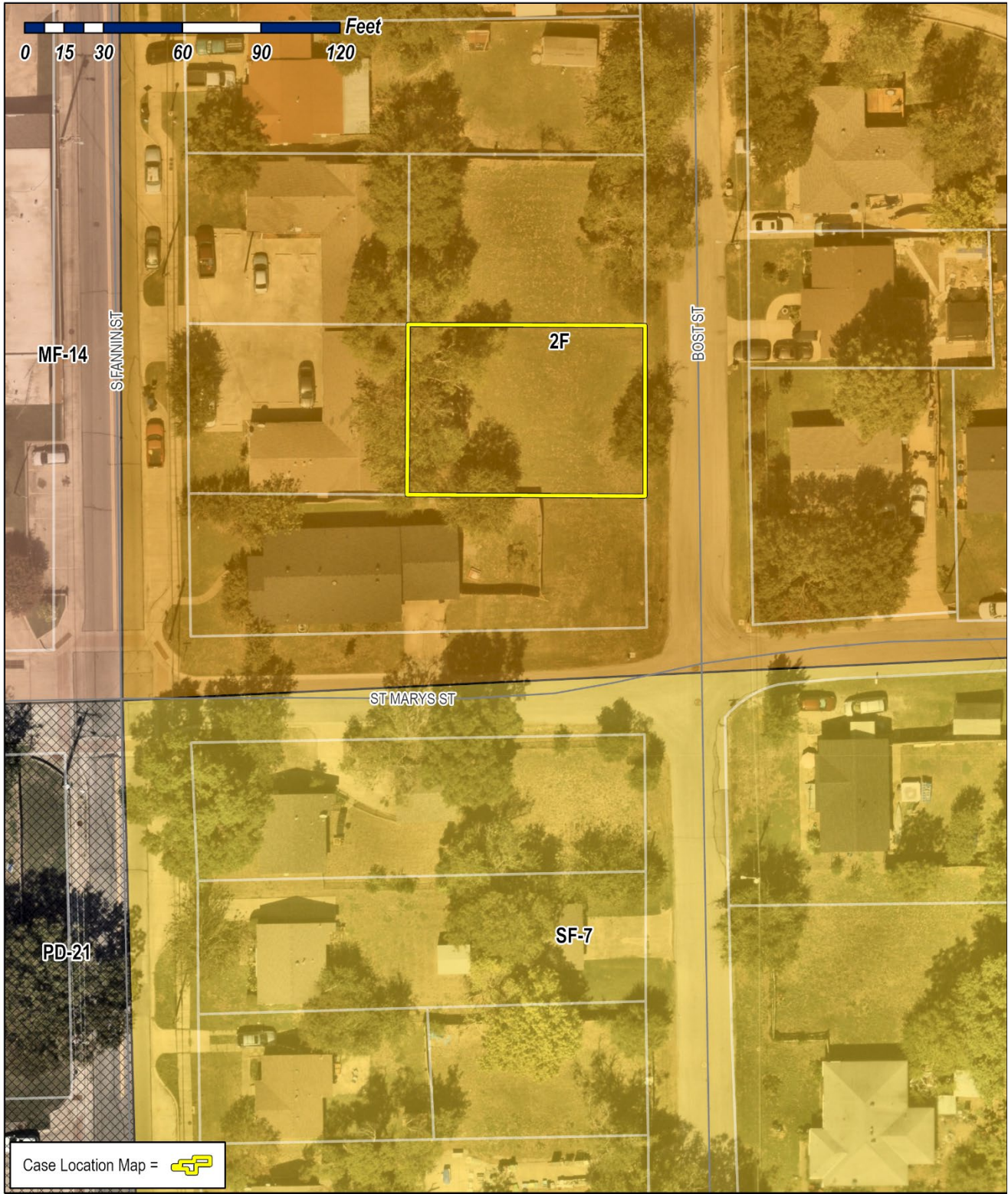
1<sup>st</sup> Reading: November 18, 2024

2<sup>nd</sup> Reading: December 2, 2024

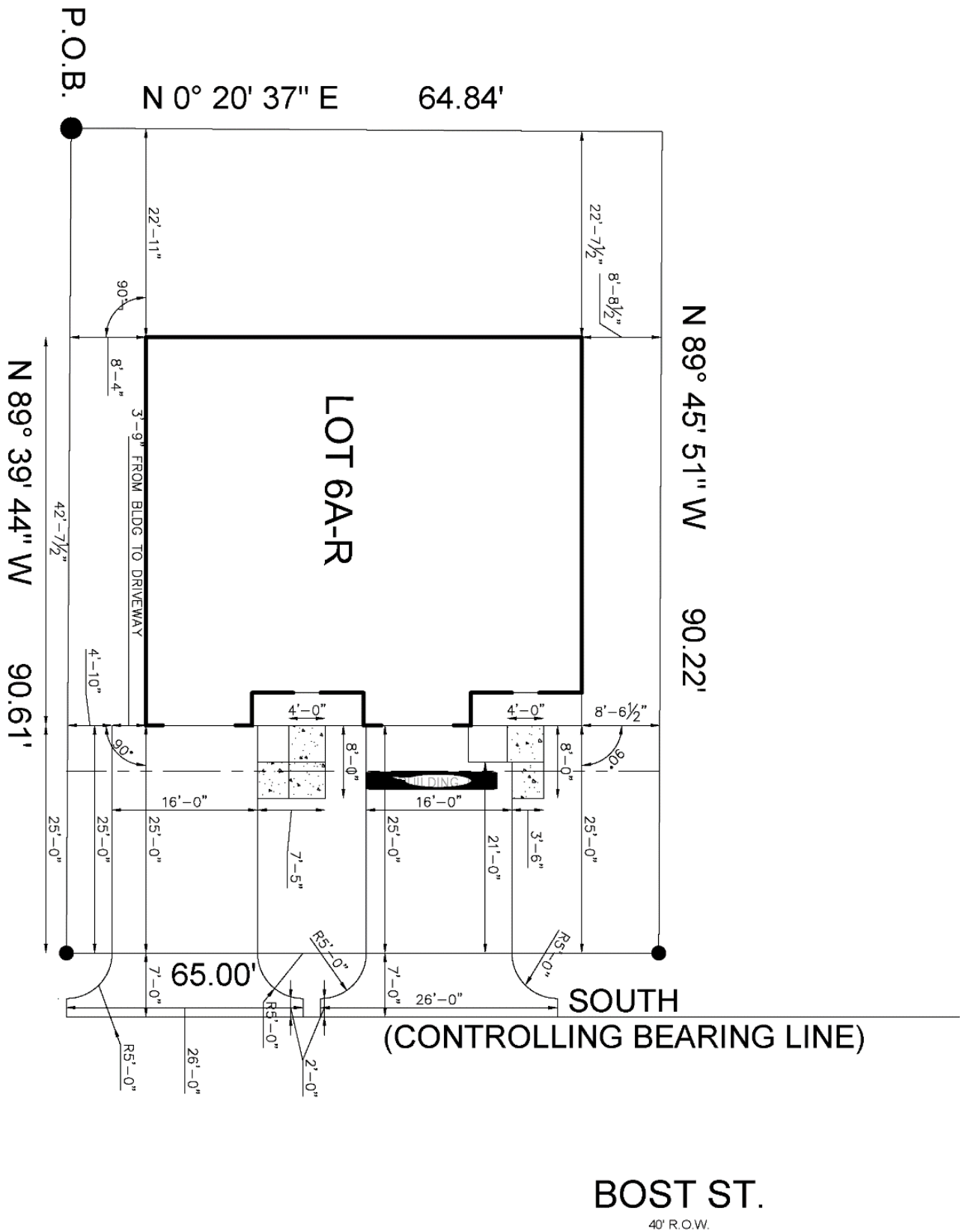
**Exhibit 'A':  
Location Map**

**Address:** West side of Bost Street and North of the intersection of St. Mary's Street and Bost Street

**Legal Description:** Lot 6A-R of the Lofland Addition



**Exhibit 'B':  
Residential Plot Plan**



**Exhibit 'C':**  
*Building Elevations*



**FRONT ELEVATION 6AR**

SCALE: 1/8" = 1'-0"



# CITY OF ROCKWALL

## PLANNING AND ZONING COMMISSION CASE MEMO

### PLANNING AND ZONING DEPARTMENT

385 S. GOLIAD STREET • ROCKWALL, TX 75087

PHONE: (972) 771-7745 • EMAIL: PLANNING@ROCKWALL.COM

**TO:** Mayor and City Council

**DATE:** December 02, 2024

**APPLICANT:** Frank Conselman; *Conselman Equities*

**CASE NUMBER:** P2024-037; *Final Plat for Lot 1, Block A, Texas Products Addition*

### SUMMARY

Consider a request by Frank Conselman of Conselman Equities for the approval of a Final Plat for Lot 1, Block A, Texas Products Addition being a 6.68-acre tract of land identified as Tracts 21 & 21-01 of the D. Harr Survey, Abstract No. 102, City of Rockwall, Rockwall County, Texas, zoned Light Industrial (LI) District, situated within the Airport Overlay (AP-OV) District, addressed as 1775 Airport Road, and take any action necessary.

### PLAT INFORMATION

- Purpose. The applicant is requesting the approval of a Final Plat for a 6.68-acre tract of land (*i.e. Tracts 21 & 21-01 of the D. Harr Survey, Abstract No. 102*) creating one (1) lot (*i.e. Lot 1, Block A, Texas Products Addition*) for the purpose of establishing the necessary easements to allow the construction of an *Office/Warehouse Facility* on the subject property.
- Background. The subject property was annexed by the City Council on March 16, 1998 by *Ordinance No. 98-10 [Case No. A1998-001]*. On February 22, 2022, the Planning and Zoning Commission approved a *Miscellaneous Case [Case No. MIS2022-001]* for a *Treescape Plan* but denied the *Alternative Tree Mitigation Settlement Agreement*. On May 2, 2022, the City Council approved a *Miscellaneous Case [i.e. Case No. MIS2022-007]* for an *Alternative Tree Mitigation Settlement Agreement* of \$7,800.00 paid into the City's Tree Fund prior to the removal of any trees on the subject property. On December 4, 2023, the City Council approved a *Zoning Change [i.e. Case No. Z2023-051]* from Agricultural (AG) District to Light Industrial (LI) District. Prior to this zoning change, there was 1,891 SF single-family home that was constructed in 1950 situated on the subject property; however, this home was razed from the property in 2023. The subject property has remained vacant since the home was removed. On April 9, 2024, the Planning and Zoning Commission approved a site plan [*i.e. Case No. SP2024-012*] for a 42,974 SF *Office/Warehouse Facility* on the subject property.
- Conformance to the Subdivision Ordinance. The surveyor has completed the majority of the technical revisions requested by staff, and this plat -- *conforming to the requirements for plats as stipulated by the Chapter 38, Subdivisions, of the Municipal Code of Ordinances* -- is recommended for conditional approval pending the completion of final technical modifications and submittal requirements.
- Conditional Approval. Conditional approval of this Final Plat by the City Council shall constitute approval subject to the conditions stipulated in the *Conditions of Approval* section below.
- With the exception of the items listed in the *Conditions of Approval* section of this case memo, this plat is in substantial compliance with the requirements of the *Subdivision Ordinance* in the *Municipal Code of Ordinances*.

### CONDITIONS OF APPROVAL

If City Council chooses to approve of the Final Plat for *Lot 1, Block A, Texas Products Addition* staff would propose the following conditions of approval:

- (1) All technical comments from the Engineering, Planning and Fire Departments shall be addressed prior to the filing of this Final Plat; and,



- (2) Any construction resulting from the approval of this Final Plat shall conform to the requirements set forth by the Unified Development Code (UDC), the International Building Code (IBC), the Rockwall Municipal Code of Ordinances, city adopted engineering and fire codes and with all other applicable regulatory requirements administered and/or enforced by the state and federal government.

**PLANNING AND ZONING COMMISSION**

On November 26, 2024, the Planning and Zoning Commission approved a motion to recommend approval of the Final Plat by a vote of 4-0, with Commissioners Conway, Deckard, and Womble absent.



# DEVELOPMENT APPLICATION

City of Rockwall  
Planning and Zoning Department  
385 S. Goliad Street  
Rockwall, Texas 75087

STAFF USE ONLY

PLANNING & ZONING CASE NO. [REDACTED]

**NOTE:** THE APPLICATION IS NOT CONSIDERED ACCEPTED BY THE CITY UNTIL THE PLANNING DIRECTOR AND CITY ENGINEER HAVE SIGNED BELOW.

DIRECTOR OF PLANNING: [REDACTED]

CITY ENGINEER: [REDACTED]

PLEASE CHECK THE APPROPRIATE BOX BELOW TO INDICATE THE TYPE OF DEVELOPMENT REQUEST [SELECT ONLY ONE BOX]:

### PLATTING APPLICATION FEES:

- MASTER PLAT (\$100.00 + \$15.00 ACRE) <sup>1</sup>
- PRELIMINARY PLAT (\$200.00 + \$15.00 ACRE) <sup>1</sup>
- FINAL PLAT (\$300.00 + \$20.00 ACRE) <sup>1</sup> ✓
- REPLAT (\$300.00 + \$20.00 ACRE) <sup>1</sup>
- AMENDING OR MINOR PLAT (\$150.00)
- PLAT REINSTATEMENT REQUEST (\$100.00)

### SITE PLAN APPLICATION FEES:

- SITE PLAN (\$250.00 + \$20.00 ACRE) <sup>1</sup>
- AMENDED SITE PLAN/ELEVATIONS/LANDSCAPING PLAN (\$100.00)

### ZONING APPLICATION FEES:

- ZONING CHANGE (\$200.00 + \$15.00 ACRE) <sup>1</sup>
- SPECIFIC USE PERMIT (\$200.00 + \$15.00 ACRE) <sup>1 & 2</sup>
- PD DEVELOPMENT PLANS (\$200.00 + \$15.00 ACRE) <sup>1</sup>

### OTHER APPLICATION FEES:

- TREE REMOVAL (\$75.00)
- VARIANCE REQUEST/SPECIAL EXCEPTIONS (\$100.00) <sup>2</sup>

### NOTES:

<sup>1</sup>: IN DETERMINING THE FEE, PLEASE USE THE EXACT ACREAGE WHEN MULTIPLYING BY THE PER ACRE AMOUNT. FOR REQUESTS ON LESS THAN ONE ACRE, ROUND UP TO ONE (1) ACRE.  
<sup>2</sup>: A \$1,000.00 FEE WILL BE ADDED TO THE APPLICATION FEE FOR ANY REQUEST THAT INVOLVES CONSTRUCTION WITHOUT OR NOT IN COMPLIANCE TO AN APPROVED BUILDING PERMIT.

## PROPERTY INFORMATION [PLEASE PRINT]

ADDRESS: 1775 AIRPORT RD.  
 SUBDIVISION: TEXAS PRODUCTS LOT: 1 BLOCK: A  
 GENERAL LOCATION: ON AIRPORT RD, EAST OF AIRPORT

## ZONING, SITE PLAN AND PLATTING INFORMATION [PLEASE PRINT]

CURRENT ZONING: PD-10/C CURRENT USE: UNDEVELOPED  
 PROPOSED ZONING: PD-10/C PROPOSED USE: OFFICE / WAREHOUSE  
 ACREAGE: 6.685 LOTS [CURRENT]: 1 LOTS [PROPOSED]: 1

**SITE PLANS AND PLATS:** BY CHECKING THIS BOX YOU ACKNOWLEDGE THAT DUE TO THE PASSAGE OF HB3167 THE CITY NO LONGER HAS FLEXIBILITY WITH REGARD TO ITS APPROVAL PROCESS, AND FAILURE TO ADDRESS ANY OF STAFF'S COMMENTS BY THE DATE PROVIDED ON THE DEVELOPMENT CALENDAR WILL RESULT IN THE DENIAL OF YOUR CASE.

## OWNER/APPLICANT/AGENT INFORMATION [PLEASE PRINT/CHECK THE PRIMARY CONTACT/ORIGINAL SIGNATURES ARE REQUIRED]

OWNER: CONSELMAN EQUITIES  APPLICANT: [REDACTED]  
 CONTACT PERSON: FRANK CONSELMAN CONTACT PERSON: [REDACTED]  
 ADDRESS: 1210 CREST COVE ADDRESS: [REDACTED]  
 CITY, STATE & ZIP: ROCKWALL, TX 75087 CITY, STATE & ZIP: [REDACTED]  
 PHONE: [REDACTED] PHONE: [REDACTED]  
 E-MAIL: Frank@TexasProducts.com E-MAIL: [REDACTED]

## NOTARY VERIFICATION [REQUIRED]

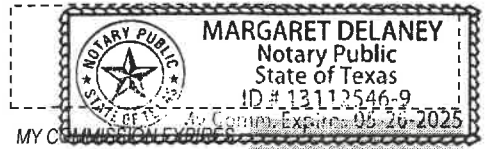
BEFORE ME, THE UNDERSIGNED AUTHORITY, ON THIS DAY PERSONALLY APPEARED [Signature] [OWNER] THE UNDERSIGNED, WHO STATED THE INFORMATION ON THIS APPLICATION TO BE TRUE AND CERTIFIED THE FOLLOWING:

"I HEREBY CERTIFY THAT I AM THE OWNER FOR THE PURPOSE OF THIS APPLICATION; ALL INFORMATION SUBMITTED HEREIN IS TRUE AND CORRECT; AND THE APPLICATION FEE OF \$1,000.00 TO COVER THE COST OF THIS APPLICATION, HAS BEEN PAID TO THE CITY OF ROCKWALL ON THIS THE 12<sup>th</sup> DAY OF November 2024 BY SIGNING THIS APPLICATION, I AGREE THAT THE CITY OF ROCKWALL (I.E. "CITY") IS AUTHORIZED AND PERMITTED TO PROVIDE INFORMATION CONTAINED WITHIN THIS APPLICATION TO THE PUBLIC. THE CITY IS ALSO AUTHORIZED AND PERMITTED TO REPRODUCE ANY COPYRIGHTED INFORMATION SUBMITTED IN CONJUNCTION WITH THIS APPLICATION, IF SUCH REPRODUCTION IS ASSOCIATED OR IN RESPONSE TO A REQUEST FOR PUBLIC INFORMATION."

GIVEN UNDER MY HAND AND SEAL OF OFFICE ON THIS THE 12<sup>th</sup> DAY OF November 2024

OWNER'S SIGNATURE

[Signature]  
 NOTARY PUBLIC IN AND FOR THE STATE OF TEXAS Margaret Delaney





P2024-037: Final Plat for Lot 1, Block A, Texas Products Addition



PD-89

Case Location Map =

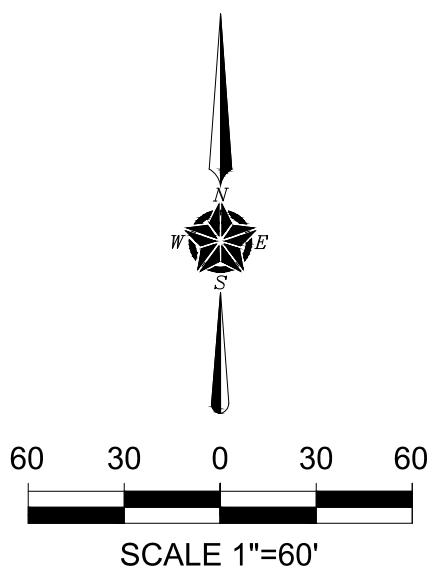
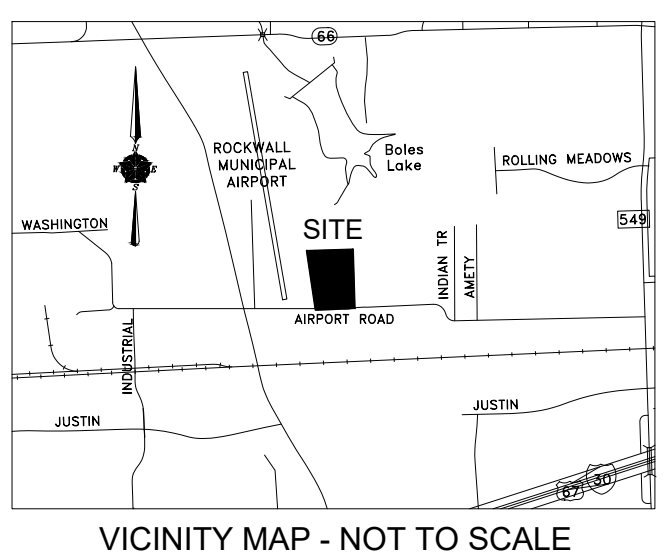
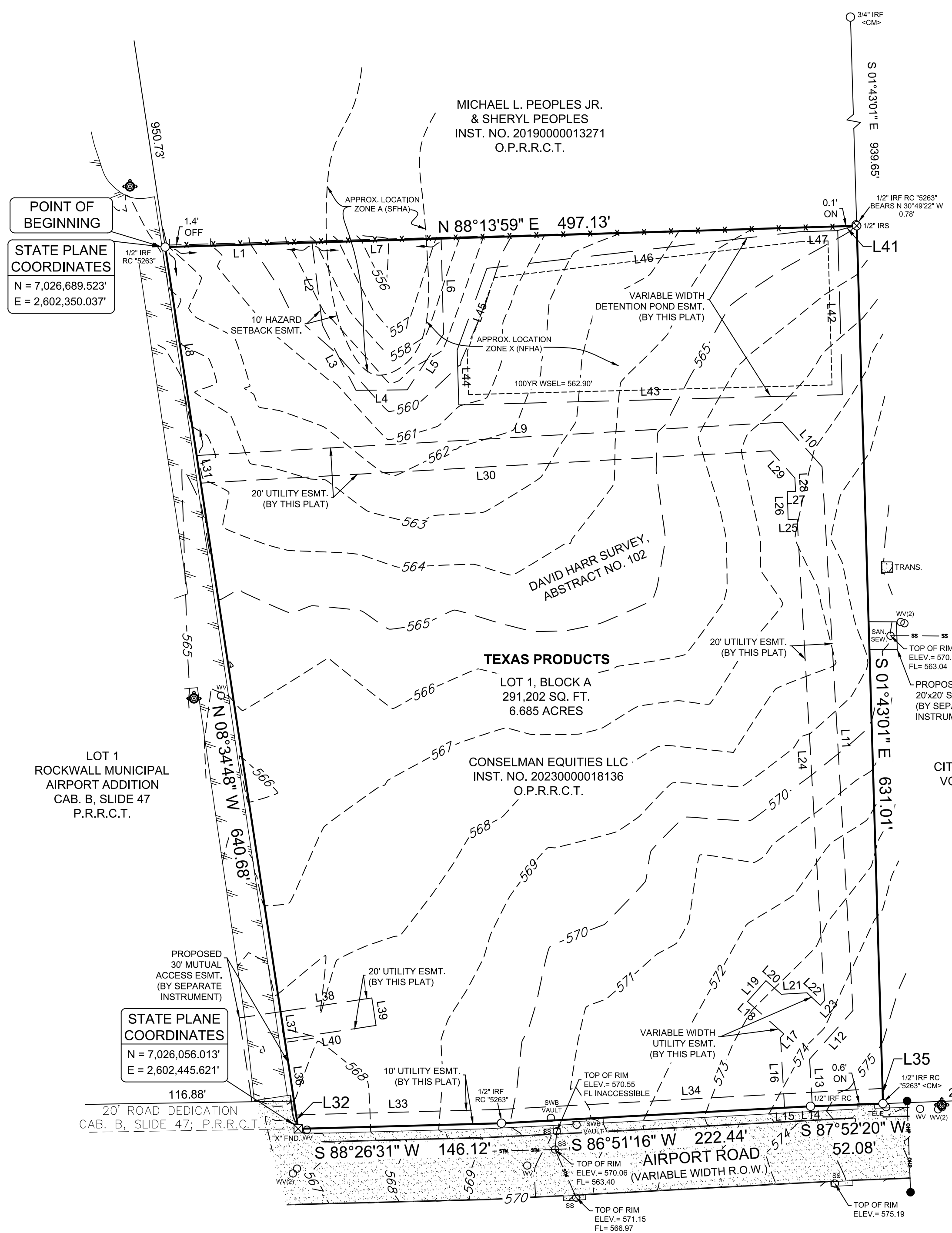


# City of Rockwall

Planning & Zoning Department  
 385 S. Goliad Street  
 Rockwall, Texas 75087  
 (P): (972) 771-7745  
 (W): www.rockwall.com

The City of Rockwall GIS maps are continually under development and therefore subject to change without notice. While we endeavor to provide timely and accurate information, we make no guarantees. The City of Rockwall makes no warranty, express or implied, including warranties of merchantability and fitness for a particular purpose. Use of the information is the sole responsibility of the user.





**GENERAL NOTES:**

- 1) Bearings are based upon the Texas State Plane Coordinate System, Texas North Central Zone (4202), North American Datum of 1983 (2011).
- 2) The purpose of this plat is to plat an unplatted tract of land into one lot.
- 3) Zoning classification: L1 (as per City of Rockwall Zoning GIS map).
- 4) Benchmark:  
COR-6  
N = 7,025942.628'; E = 2,601204.043'; Elevation = 558.61'
- 5) There are no trees on the subject property.
- 6) According to the F.I.R.M. No. 48397C0045L, the subject property lies in Zone A and Zone X and does partially lie within a Special Flood Hazard Area, as shown.

EASEMENT LINE TABLE		
LINE #	LENGTH	DIRECTION
L1	105.52'	N88°13'59"E
L2	59.75'	S7°12'04"E
L3	52.71'	S27°16'42"E
L4	36.85'	N89°27'57"E
L5	47.79'	N33°01'53"E
L6	68.54'	N1°27'19"W
L7	92.85'	S88°16'25"W
L8	151.43'	S8°34'48"E
L9	421.58'	N86°44'54"E
L10	42.81'	S41°44'54"E
L11	391.37'	S3°15'06"E
L12	46.77'	S41°44'54"W
L13	33.94'	S3°15'06"E
L14	1.23'	S87°52'20"W
L15	18.77'	S86°51'16"W
L16	50.56'	N3°15'06"W
L17	3.50'	N41°44'54"E
L18	34.98'	N48°15'06"W
L19	20.00'	N41°44'54"E
L20	14.65'	S48°15'06"E
L21	18.57'	N86°44'54"E
L22	13.14'	S46°47'16"E
L23	4.54'	N41°44'54"E
L24	346.45'	N3°15'06"W
L25	6.50'	S88°16'59"W

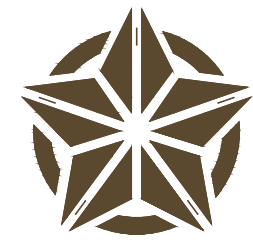
EASEMENT LINE TABLE		
LINE #	LENGTH	DIRECTION
L26	20.00'	N1°43'01"W
L27	5.96'	N88°16'59"E
L28	9.65'	N3°15'06"W
L29	26.18'	N41°44'54"W
L30	410.07'	S86°44'54"W
L31	20.09'	N8°34'48"W
L32	10.08'	N8°34'48"W
L33	147.21'	S88°26'31"W
L34	274.65'	S86°51'16"W
L35	10.93'	S1°43'01"E
L36	55.03'	N8°34'48"W
L37	20.00'	S8°34'48"E
L38	66.35'	S81°25'12"W
L39	20.00'	N8°34'48"W
L40	66.35'	S81°25'12"W
L41	14.08'	S75°40'30"W
L42	117.92'	S1°36'04"E
L43	275.65'	S88°28'03"W
L44	39.46'	N1°43'01"W
L45	62.46'	N20°02'25"E
L46	225.62'	N83°18'29"E
L47	27.97'	N88°16'59"E

- LEGEND:**
- <CM> CONTROLLING MONUMENT
  - "X" FND. X "X" CUT IN CONCRETE FOUND
  - IRF O IRON ROD FOUND
  - IRS O IRON ROD WITH YELLOW PLASTIC CAP STAMPED "TXHS" SET
  - RC RED CAP
  - YC YELLOW CAP
  - P.R.R.C.T. PLAT RECORDS, ROCKWALL COUNTY, TEXAS
  - O.P.R.R.C.T. OFFICIAL PUBLIC RECORDS, ROCKWALL COUNTY, TEXAS
  - VOL., PG. VOLUME, PAGE
  - CAB., SLIDE CABINET, SLIDE
  - INST. NO. INSTRUMENT NUMBER
  - SQ. FT. SQUARE FEET
  - ESMT EASEMENT
  - ELEV. ELEVATION
  - FL FLOW LINE
  - TRANS. TRANSFORMER
  - POWER POLE
  - WV O FIRE HYDRANT
  - SWB V O WATER VALVE
  - SS O TELEPHONE PEDESTAL
  - SAN. SEW. O SANITARY SEWER MANHOLE
  - SS SANITARY SEWER LINE
  - SS STORM SEWER MANHOLE
  - SS STORM SEWER LINE
  - ASPHLT ASPHALT
  - CONCRETE PAVING CONCRETE PAVING

SURVEYOR

**TEXAS HERITAGE SURVEYING, LLC**

10610 Metric Drive, Suite 124, Dallas, TX 75243  
Office 214-340-9700 Fax 214-340-9710  
txheritage.com  
Firm No. 10169300



**ENGINEER**  
MONK CONSULTING ENGINEERS, INC.  
1200 W. STATE STREET  
GARLAND, TEXAS 75040  
attn: JERRY MONK

**OWNER**  
CONSELMAN EQUITIES LLC,  
A TEXAS LIMITED LIABILITY COMPANY  
1210 CRESTCOVE  
ROCKWALL, TEXAS 75087

**PRELIMINARY PLAT**  
**LOT 1, BLOCK A**  
**TEXAS PRODUCTS**  
BEING ONE LOT  
291,202 SQUARE FEET / 6.685 ACRES  
SITUATED IN THE  
DAVID HARR SURVEY, ABSTRACT NO. 102  
CITY OF ROCKWALL, ROCKWALL COUNTY, TEXAS  
CASE NO.

OWNER'S CERTIFICATE:

STATE OF TEXAS  
COUNTY OF ROCKWALL

WHEREAS, CONSELMAN EQUITIES LLC, a Texas limited liability company is the owner of a tract of land situated in the David Harr Survey, Abstract No. 102 in the City of Rockwall, Rockwall County, Texas, being that tract of land described in General Warranty Deed to CONSELMAN EQUITIES LLC recorded in Instrument Number 20230000018136 of the Official Public Records of Rockwall County, Texas, and being more particularly described by metes and bounds as follows:

Beginning at a 1/2 inch iron rod with red plastic cap stamped "5263" found for corner, said corner being in the east line of Lot 1 of Rockwall Municipal Airport Addition, an addition to the City of Rockwall, Rockwall County, Texas according to the plat thereof recorded in Cabinet B, Slide 47 of the Plat Records of Rockwall County, Texas, said corner also being the southwest corner of that tract of land described in Warranty Deed with Vendor's Lien to Michael L. Peoples Jr. & Sheryl Peoples recorded in Instrument Number 20190000013271 of the Official Public Records of Rockwall County, Texas, and being the northwest corner of the herein described tract;

Thence North 88 degrees 13 minutes 59 seconds East, along the south line of said Peoples tract, a distance of 497.12 feet to a 1/2 inch iron rod with yellow plastic cap stamped "TXHS" set for corner, said corner being in the west line of that tract of land described in General Warranty Deed to City of Rockwall recorded in Volume 4358, Page 101 of the Official Public Records of Rockwall County, Texas, from which lies a 1/2 inch iron rod with red plastic cap stamped "5263" found which bears North 30 degrees 49 minutes 22 seconds West, 0.78 feet;

Thence South 01 degrees 43 minutes 01 seconds East, along the west line of said City of Rockwall tract, a distance of 631.01 feet to a 1/2 inch iron rod with red plastic cap stamped "5263" found for corner, said corner being in the north right-of-way line of Airport Road (variable width right-of-way);

Thence South 87 degrees 52 minutes 20 seconds West, along the north right-of-way line of said Airport Road, a distance of 52.08 feet to a 1/2 inch iron rod with red plastic cap found for corner;

Thence South 86 degrees 51 minutes 16 seconds West, continuing along the north right-of-way line of said Airport Road, a distance of 222.44 feet to a 1/2 inch iron rod with red plastic cap stamped "5263" found for corner;

Thence South 88 degrees 26 minutes 31 seconds West, continuing along the north right-of-way line of said Airport Road, a distance of 146.12 feet to an "X" cut in concrete found for corner, said corner being the southeast corner of a 20 foot road dedication, as dedicated by said Rockwall Municipal Airport Addition;

Thence North 08 degrees 34 minutes 48 seconds West, along the east line of said 20 foot road dedication and said Lot 1, a distance of 640.68 feet to the POINT OF BEGINNING and containing 291,202 square feet or 6.685 acres of land, more or less.

CITY OF ROCKWALL PLAT NOTES:

1) Subdivider's Statement: Selling a portion of this addition by metes and bounds is unlawful and a violation of the Subdivision Ordinance of the City of Rockwall and Chapter 212, Municipal Regulation of Subdivisions and Property Development, of the Texas Local Government Code, and shall be subject to the City of Rockwall withholding utilities and building permits.

2) Public Improvement Statement: It shall be the policy of the City of Rockwall to withhold issuing building permits until all streets, water, sewer and storm drainage systems have been accepted by the City. The approval of a subdivision plat by the City does not constitute any representation, assurance or guarantee that any building within such plat shall be approved, authorized or permit issued, nor shall such approval constitute any representation, assurance or guarantee by the City of Rockwall of the adequacy and availability for water and sanitary sewer for personal use and fire protection within such subdivision plat, as required under the Subdivision Ordinance of the City of Rockwall.

3) Drainage and Detention Easements: Property owner shall be responsible for maintaining, repairing, and replacing and shall bear sole liability of all systems within the drainage and detention easements.

4) Fire Lanes: All Fire Lanes will be constructed, maintained, repaired and replaced by the property owner. Fire Lanes shall be constructed in accordance with the approved Civil Engineering Plans for both on-site and off-site Fire Lane improvements.

5) Street Appurtenances: All decorative signage, posts, or lights installed in public right-of-way shall be installed, maintained, repaired, and replaced by the homeowner's association (HOA).

OWNER'S DEDICATION:

NOW THEREFORE, KNOW ALL MEN BY THESE PRESENTS:

STATE OF TEXAS  
COUNTY OF ROCKWALL

I the undersigned owner of the land shown on this plat, and designated herein as the TEXAS PRODUCTS subdivision to the City of Rockwall, Texas, and whose name is subscribed hereto, hereby dedicate to the use of the public forever all streets, alleys, parks, water courses, drains, easements and public places thereon shown on the purpose and consideration therein expressed. I further certify that all other parties who have a mortgage or lien interest in the TEXAS PRODUCTS subdivision have been notified and signed this plat. I understand and do hereby reserve the easement strips shown on this plat for the purposes stated and for the mutual use and accommodation of all utilities desiring to use or using same. I also understand the following;

1. No buildings shall be constructed or placed upon, over, or across the utility easements as described herein.
2. Any public utility shall have the right to remove and keep removed all or part of any buildings, fences, trees, shrubs, or other growths or improvements which in any way endanger or interfere with construction, maintenance or efficiency of their respective system on any of these easement strips; and any public utility shall at all times have the right of ingress or egress to, from and upon the said easement strips for purposes of construction, reconstruction, inspecting, patrolling, maintaining, and either adding to or removing all or part of their respective system without the necessity of, at any time, procuring the permission of anyone.
3. The City of Rockwall will not be responsible for any claims of any nature resulting from or occasioned by the establishment of grade of streets in the subdivision.
4. The developer/property owner and subdivision engineer shall bear total responsibility for storm drain improvements.
5. The developer/property owner shall be responsible for the necessary facilities to provide drainage patterns and drainage controls such that properties within the drainage area are not adversely affected by storm drainage from the development.
6. No house dwelling unit, or other structure shall be constructed on any lot in this addition by the owner or any other person until the developer and/or owner has complied with all requirements of the Subdivision Regulations of the City of Rockwall regarding improvements with respect to the entire block on the street or streets on which property abuts, including the actual installation of streets with the required base and paving, curb and gutter, water and sewer, drainage structures, storm structures, storm sewers, and alleys, all according to the specifications of the City of Rockwall; or

Until an escrow deposit, sufficient to pay for the cost of such improvements, as determined by the city's engineer and/or city administrator, computed on a private commercial rate basis, has been made with the city secretary, accompanied by an agreement signed by the developer and/or owner, authorizing the city to make such improvements at prevailing private commercial rates, or have the same made by a contractor and pay for the same out of the escrow deposit, should the developer and/or owner fail or refuse to install the required improvements within the time stated in such written agreement, but in no case shall the City be obligated to make such improvements itself. Such deposit may be used by the owner and/or developer as progress payments as the work progresses in making such improvements by making certified requisitions to the city secretary, supported by evidence of work done; or

Until the developer and/or owner files a corporate surety bond with the city secretary in a sum equal to the cost of such improvements for the designated area, guaranteeing the installation thereof within the time stated in the bond, which time shall be fixed by the city council of the City of Rockwall.

I further acknowledge that the dedications and/or exaction's made herein are proportional to the impact of the Subdivision upon the public services required in order that the development will comport with the present and future growth needs of the City; I, my successors and assigns hereby waive any claim, damage or cause of action that I may have as a result of the dedication of exactions made herein.

CONSELMAN EQUITIES LLC, a Texas limited liability company

Frank Conselman  
President

STATE OF TEXAS  
COUNTY OF DALLAS

BEFORE ME, the undersigned authority, on this day personally appeared Frank Conselman, known to me to be the person whose name is subscribed to the foregoing instrument, and acknowledged to me that he executed the same for the purposes and considerations therein stated.

GIVEN UNDER MY HAND AND SEAL OF OFFICE, this \_\_\_\_\_ day of \_\_\_\_\_, 2024.

Notary Signature

SURVEYORS CERTIFICATE:

I, J. R. January, do hereby certify that I prepared this plat from an actual and accurate survey of the land, and that the corner monuments shown thereon were properly placed under my personal supervision.

**PRELIMINARY**, THIS DOCUMENT SHALL NOT BE RECORDED FOR ANY PURPOSES AND SHALL NOT BE USED OR VIEWED OR RELIED UPON AS A FINAL SURVEY DOCUMENT. (11/7/2024)

J. R. January, R.P.L.S. No. 5382

**APPROVED:** I hereby certify that the above and foregoing Subdivision Plat was reviewed by the Planning and Zoning Commission and approved by the City Council of the City of Rockwall, Texas for the preparation of a Final Plat on the \_\_\_\_\_ day of \_\_\_\_\_, 2024.

Mayor of the City of Rockwall

Planning and Zoning Chairman

City Secretary

City Engineer

SURVEYOR

**TEXAS HERITAGE**  
**SURVEYING, LLC**



10610 Metric Drive, Suite 124, Dallas, TX 75243  
Office 214-340-9700 Fax 214-340-9710  
txheritage.com  
Firm No. 10169300

**PRELIMINARY PLAT**  
**LOT 1, BLOCK A**  
**TEXAS PRODUCTS**  
BEING ONE LOT  
291,202 SQUARE FEET / 6.685 ACRES  
SITUATED IN THE  
DAVID HARR SURVEY, ABSTRACT NO. 102  
CITY OF ROCKWALL, ROCKWALL COUNTY, TEXAS  
CASE NO.

PAGE 2 OF 2

DATE: 11/6/2024 / JOB # 2302034-2 / SCALE= 1" = 60' / DRAWN: JACOB

**ENGINEER**  
MONK CONSULTING ENGINEERS, INC.  
1200 W. STATE STREET  
GARLAND, TEXAS 75040  
attn: JERRY MONK

**OWNER**  
CONSELMAN EQUITIES LLC,  
A TEXAS LIMITED LIABILITY COMPANY  
1210 CRESTCOVE  
ROCKWALL, TEXAS 75087



# CITY OF ROCKWALL

## CITY COUNCIL CASE MEMO

### PLANNING AND ZONING DEPARTMENT

385 S. GOLIAD STREET • ROCKWALL, TX 75087

PHONE: (972) 771-7745 • EMAIL: PLANNING@ROCKWALL.COM

---

**TO:** Mayor and City Council  
**DATE:** December 02, 2024  
**APPLICANT:** Matthew J. Peterson; *DB Constructors, Inc.*  
**CASE NUMBER:** P2024-039; *Replat for Lot 4, Block B, Rockwall Technology Park, Phase 2 Addition*

---

### SUMMARY

Consider a request by Matthew J. Peterson of DB Constructors, Inc. on behalf of Phil Wagner of the Rockwall Economic Development Corporation (REDC) for the approval of a Replat for Lot 4, Block B, Rockwall Technology Park, Phase 2 being a 10.65-acre parcel of land identified as Lot 2, Block B, Rockwall Technology Park, Phase 2, City of Rockwall, Rockwall County, Texas, zoned Light Industrial (LI) District, situated within the FM-549 Overlay (FM-549 OV) District, addressed as 2911 Corporate Crossing, and take any action necessary.

### PLAT INFORMATION

- Purpose. The applicant is requesting the approval of a Replat for a 10.65-acre tract of land (*i.e. Lot 2, Block B, Rockwall Technology Park, Phase 2 Addition*), establishing one (1) lot (*i.e. Lot 4, Block B, Rockwall Technology Park, Phase 2 Addition*) for the purpose of facilitating the construction of a *Light Manufacturing Facility* on the subject property.
- Background. A portion of the subject property was originally annexed into the City of Rockwall on May 19, 1986 by *Ordinance No. 86-37*. At the time of annexation this portion of the subject property was zoned Agricultural (AG) District. According to the City's *Historic Zoning Maps*, between annexation and December 7, 1993 this portion of the subject property was rezoned from an Agricultural (AG) District to a Commercial (C) District. The remainder of the subject property was annexed into the City of Rockwall on July 21, 1997 by *Ordinance No. 97-14*. At the time of annexation, this portion of the subject property was zoned Agricultural (AG) District. On May 29, 2003, the two (2) portions of the subject property had been assembled as a portion of Lot 1, Block B, Rockwall Technology Park, Phase 2 Addition. By April 5, 2005 the subject property had been rezoned to a Light Industrial (LI) District. On December 5, 2014, the subject property was replatted as Lot 2, Block B, Rockwall Technology Park, Phase 2 Addition [*i.e. Case No. P2014-036*] (*listed as Lot 1, Block B, Rockwall Technology Park, Phase 2 Addition by the Rockwall Central Appraisal District [RCAD] on the certified tax role*). The subject property has remained vacant since the time of annexation. On July 5, 2022, City Council approved a Specific Use Permit (SUP) [*i.e. Case No. Z2022-022*] to allow for a 2,800 SF *General Retail Store* as part of a larger 189,000 SF *Light Manufacturing Facility* on the subject property. On July 12, 2022, the Planning and Zoning Commission approved a site plan (*i.e. Case No. SP2022-034*) for a *Light Manufacturing Facility* with a *General Retail Store* on the subject property.
- Conformance to the Subdivision Ordinance. The surveyor has completed the majority of the technical revisions requested by staff, and this plat -- *conforming to the requirements for plats as stipulated by the Chapter 38, Subdivisions, of the Municipal Code of Ordinances* -- is recommended for conditional approval pending the completion of final technical modifications and submittal requirements.
- Conditional Approval. Conditional approval of this Replat by the City Council shall constitute approval subject to the conditions stipulated in the *Conditions of Approval* section below.
- With the exception of the items listed in the Conditions of Approval section of this case memo, this plat is in substantial compliance with the requirements of the Subdivision Ordinance in the Municipal Code of Ordinances.



# DEVELOPMENT APPLICATION

City of Rockwall  
Planning and Zoning Department  
385 S. Goliad Street  
Rockwall, Texas 75087

**STAFF USE ONLY**

PLANNING & ZONING CASE NO. \_\_\_\_\_

**NOTE: THE APPLICATION IS NOT CONSIDERED ACCEPTED BY THE CITY UNTIL THE PLANNING DIRECTOR AND CITY ENGINEER HAVE SIGNED BELOW.**

DIRECTOR OF PLANNING: \_\_\_\_\_

CITY ENGINEER: \_\_\_\_\_

PLEASE CHECK THE APPROPRIATE BOX BELOW TO INDICATE THE TYPE OF DEVELOPMENT REQUEST [SELECT ONLY ONE BOX]:

**PLATTING APPLICATION FEES:**

- MASTER PLAT (\$100.00 + \$15.00 ACRE) <sup>1</sup>
- PRELIMINARY PLAT (\$200.00 + \$15.00 ACRE) <sup>1</sup>
- FINAL PLAT (\$300.00 + \$20.00 ACRE) <sup>1</sup>
- REPLAT (\$300.00 + \$20.00 ACRE) <sup>1</sup>
- AMENDING OR MINOR PLAT (\$150.00)
- PLAT REINSTATEMENT REQUEST (\$100.00)

**SITE PLAN APPLICATION FEES:**

- SITE PLAN (\$250.00 + \$20.00 ACRE) <sup>1</sup>
- AMENDED SITE PLAN/ELEVATIONS/LANDSCAPING PLAN (\$100.00)

**ZONING APPLICATION FEES:**

- ZONING CHANGE (\$200.00 + \$15.00 ACRE) <sup>1</sup>
- SPECIFIC USE PERMIT (\$200.00 + \$15.00 ACRE) <sup>1 & 2</sup>
- PD DEVELOPMENT PLANS (\$200.00 + \$15.00 ACRE) <sup>1</sup>

**OTHER APPLICATION FEES:**

- TREE REMOVAL (\$75.00)
- VARIANCE REQUEST/SPECIAL EXCEPTIONS (\$100.00) <sup>2</sup>

**NOTES:**

<sup>1</sup> IN DETERMINING THE FEE, PLEASE USE THE EXACT ACREAGE WHEN MULTIPLYING BY THE PER ACRE AMOUNT. FOR REQUESTS ON LESS THAN ONE ACRE, ROUND UP TO ONE (1) ACRE.  
<sup>2</sup> A \$1,000.00 FEE WILL BE ADDED TO THE APPLICATION FEE FOR ANY REQUEST THAT INVOLVES CONSTRUCTION WITHOUT OR NOT IN COMPLIANCE TO AN APPROVED BUILDING PERMIT.

**PROPERTY INFORMATION [PLEASE PRINT]**

ADDRESS: 2911 Discovery Boulevard, Rockwall, Texas

SUBDIVISION: Rockwall Technology Park, Phase II      LOT: 1      BLOCK: B

GENERAL LOCATION: SE Corner of Discovery Blvd. and Corporate Crossing

**ZONING, SITE PLAN AND PLATTING INFORMATION [PLEASE PRINT]**

CURRENT ZONING: Light Industrial with SUP for factory store

CURRENT USE: Undeveloped

PROPOSED ZONING:

PROPOSED USE: Office/Manufacturing/Warehouse/Factory Store

ACREAGE: 10.65

LOTS [CURRENT]: 1

LOTS [PROPOSED]: 1

**SITE PLANS AND PLATS:** BY CHECKING THIS BOX YOU ACKNOWLEDGE THAT DUE TO THE PASSAGE OF HB3167 THE CITY NO LONGER HAS FLEXIBILITY WITH REGARD TO ITS APPROVAL PROCESS, AND FAILURE TO ADDRESS ANY OF STAFF'S COMMENTS BY THE DATE PROVIDED ON THE DEVELOPMENT CALENDAR WILL RESULT IN THE DENIAL OF YOUR CASE.

**OWNER/APPLICANT/AGENT INFORMATION [PLEASE PRINT/CHECK THE PRIMARY CONTACT/ORIGINAL SIGNATURES ARE REQUIRED]**

OWNER: Rockwall EDC

APPLICANT: DB Constructors, Inc

CONTACT PERSON: Phil Wagner

CONTACT PERSON: Matthew J Peterson

ADDRESS: 2610 Observation Trail, Suite 104

ADDRESS: 2400 Great Southwest Parkway

CITY, STATE & ZIP: Rockwall, TX 75032

CITY, STATE & ZIP: Fort Worth, Texas 76106

PHONE: 972-772-0025

PHONE: 972-837-6244

E-MAIL: pwagner@rockwalledc.com

E-MAIL: matthew@dbconstructors.com

**NOTARY VERIFICATION [REQUIRED]**

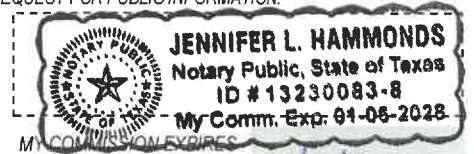
BEFORE ME, THE UNDERSIGNED AUTHORITY, ON THIS DAY PERSONALLY APPEARED Phil Wagner [OWNER] THE UNDERSIGNED, WHO STATED THE INFORMATION ON THIS APPLICATION TO BE TRUE AND CERTIFIED THE FOLLOWING:

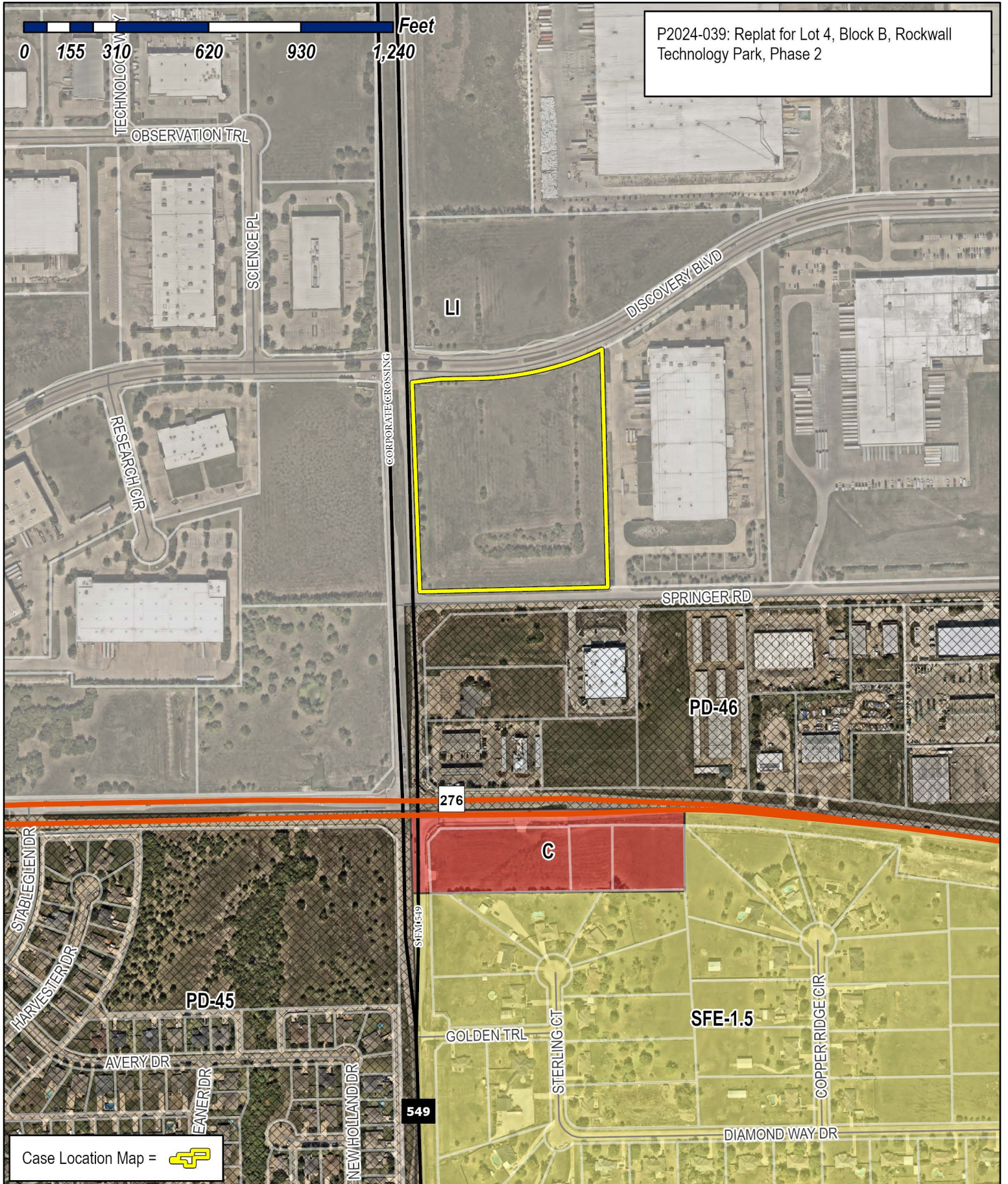
"I HEREBY CERTIFY THAT I AM THE OWNER FOR THE PURPOSE OF THIS APPLICATION; ALL INFORMATION SUBMITTED HEREIN IS TRUE AND CORRECT; AND THE APPLICATION FEE OF \$ 513.00 TO COVER THE COST OF THIS APPLICATION, HAS BEEN PAID TO THE CITY OF ROCKWALL ON THIS THE 15th DAY OF November 2024. BY SIGNING THIS APPLICATION, I AGREE THAT THE CITY OF ROCKWALL (I.E. "CITY") IS AUTHORIZED AND PERMITTED TO PROVIDE INFORMATION CONTAINED WITHIN THIS APPLICATION TO THE PUBLIC. THE CITY IS ALSO AUTHORIZED AND PERMITTED TO REPRODUCE ANY COPYRIGHTED INFORMATION SUBMITTED IN CONJUNCTION WITH THIS APPLICATION, IF SUCH REPRODUCTION IS ASSOCIATED OR IN RESPONSE TO A REQUEST FOR PUBLIC INFORMATION."

GIVEN UNDER MY HAND AND SEAL OF OFFICE ON THIS THE 13th DAY OF November, 2024


OWNER'S SIGNATURE: Phil Wagner

NOTARY PUBLIC IN AND FOR THE STATE OF TEXAS: Jennifer L. Hammonds





P2024-039: Replat for Lot 4, Block B, Rockwall Technology Park, Phase 2

Case Location Map = 



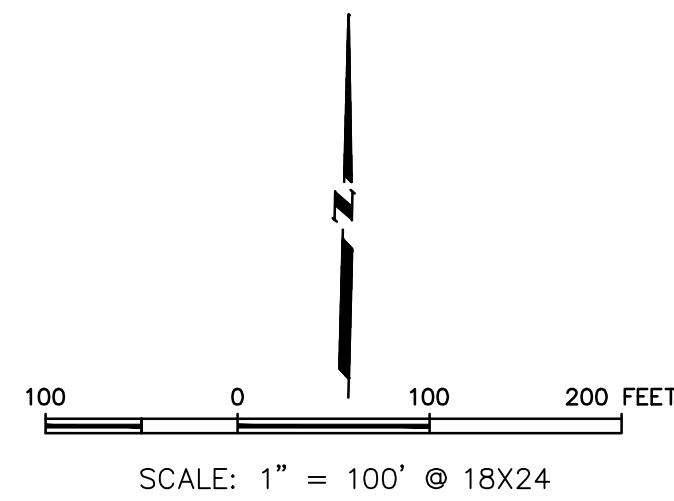
# City of Rockwall

Planning & Zoning Department  
 385 S. Goliad Street  
 Rockwall, Texas 75087  
 (P): (972) 771-7745  
 (W): www.rockwall.com

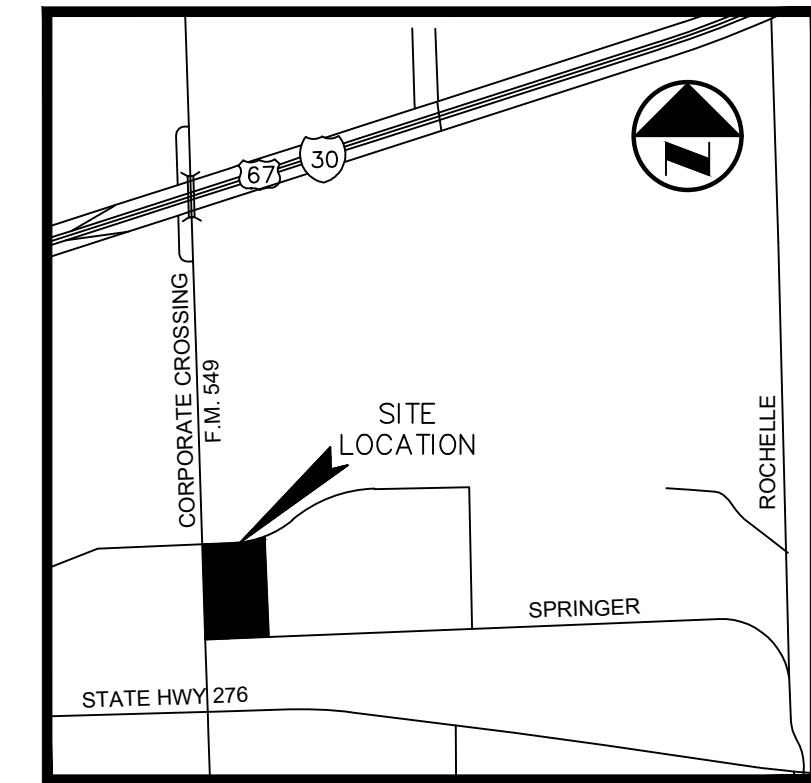
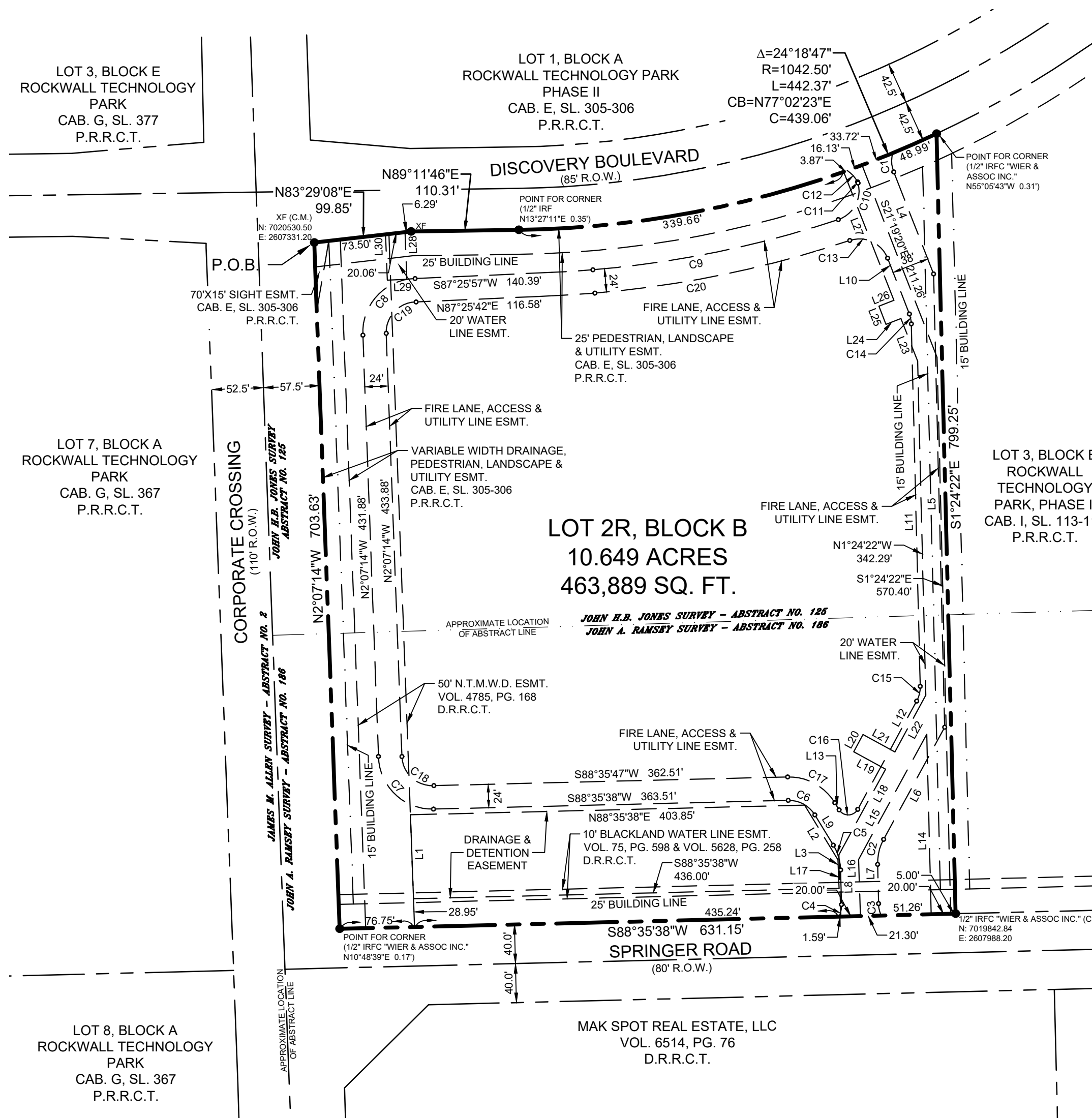
The City of Rockwall GIS maps are continually under development and therefore subject to change without notice. While we endeavor to provide timely and accurate information, we make no guarantees. The City of Rockwall makes no warranty, express or implied, including warranties of merchantability and fitness for a particular purpose. Use of the information is the sole responsibility of the user.







LINE TABLE		
NO.	BEARING	LENGTH
L1	N02°07'14"W	86.06'
L2	S31°26'13"E	65.64'
L3	S02°07'14"E	29.22'
L4	S21°19'20"E	112.20'
L5	S01°24'22"E	464.49'
L6	S28°33'47"W	130.77'
L7	S01°24'22"E	40.21'
L8	S01°24'22"E	35.49'
L9	S31°26'13"E	36.45'
L10	S21°19'20"E	61.39'
L11	S01°24'22"E	371.43'
L12	S28°33'47"W	126.28'
L13	S31°26'13"E	8.61'
L14	N01°24'22"W	184.56'
L15	S28°33'47"W	146.04'
L16	S01°47'28"E	58.05'
L17	N01°47'28"W	63.34'
L18	N28°33'47"E	99.87'
L19	N61°26'13"W	37.18'
L20	N28°33'47"E	20.00'
L21	S61°26'13"E	37.18'
L22	N28°33'47"E	66.28'
L23	N21°19'20"W	46.91'
L24	S68°40'40"W	16.47'
L25	N21°19'20"W	20.00'
L26	N68°40'40"E	16.47'
L27	N21°19'20"W	141.30'
L28	S02°12'35"E	48.43'
L29	S87°47'25"W	20.00'
L30	N02°12'35"W	46.92'



LOCATION MAP  
NOT TO SCALE

CURVE TABLE					
NO.	DELTA	RADIUS	LENGTH	CHORD BEARING	CHORD
C1	36°23'40"	31.00'	19.69'	S03°07'30"E	19.36'
C2	29°58'09"	51.00'	26.68'	S13°34'43"W	26.37'
C3	24°37'35"	29.37'	12.62'	S12°23'34"E	12.53'
C4	23°13'24"	31.00'	12.57'	N10°12'20"E	12.48'
C5	30°01'51"	51.00'	26.73'	N16°25'17"W	26.43'
C6	59°58'09"	31.00'	32.45'	N61°25'17"W	30.99'
C7	90°19'38"	55.00'	86.71'	S46°14'33"E	78.00'
C8	91°38'25"	55.00'	87.97'	S42°39'28"W	78.89'
C9	13°33'30"	1087.00'	257.22'	N78°26'33"E	256.62'
C10	86°36'21"	31.00'	46.86'	N28°21'37"E	42.52'
C11	12°45'34"	6.00'	1.34'	N21°19'20"W	1.33'
C12	29°13'35"	31.00'	15.81'	N42°18'55"W	15.64'
C13	87°14'22"	31.00'	47.20'	N64°56'32"W	42.77'
C14	19°54'58"	30.00'	10.43'	N11°21'51"W	10.38'
C15	29°58'09"	30.00'	15.69'	N13°34'43"E	15.51'
C16	120°00'00"	11.00'	23.04'	N88°33'47"E	19.05'
C17	59°58'09"	55.00'	57.57'	N61°25'17"W	54.97'
C18	91°08'03"	31.00'	49.31'	S47°41'16"E	44.27'
C19	91°24'19"	31.00'	49.46'	S43°34'55"W	44.37'
C20	13°47'03"	1111.00'	267.28'	N78°19'46"E	266.64'

NOTES:

- THE BASIS OF BEARINGS FOR THIS SURVEY IS THE STATE PLANE COORDINATE SYSTEM, NORTH TEXAS CENTRAL ZONE 4202, NORTH AMERICAN DATUM OF 1983. ADJUSTMENT REALIZATION 2011.
- COORDINATES SHOWN ARE BASED ON THE STATE PLANE COORDINATE SYSTEM, NORTH TEXAS CENTRAL ZONE 4202, NORTH AMERICAN DATUM OF 1983 ON GRID COORDINATE VALUES, NO SCALE AND NO PROJECTION.
- THE PURPOSE OF THIS REPLAT IS FOR DEVELOPMENT.
- THE SURVEY ABSTRACT LINES SHOWN HEREON ARE APPROXIMATE AND ARE NOT LOCATED ON THE GROUND.
- IT SHALL BE THE POLICY OF THE CITY OF ROCKWALL TO WITHHOLD ISSUING BUILDING PERMITS UNTIL ALL STREETS, WATER, SEWER AND STORM DRAINAGE SYSTEMS HAVE BEEN ACCEPTED BY THE CITY. THE APPROVAL OF A PLAT BY THE CITY DOES NOT CONSTITUTE ANY REPRESENTATION, ASSURANCE OR GUARANTEE THAT ANY BUILDING WITHIN SUCH PLAT SHALL BE APPROVED, AUTHORIZED OR PERMIT THEREFORE ISSUED, NOR SHALL SUCH APPROVAL CONSTITUTE ANY REPRESENTATION, ASSURANCE OR GUARANTEE BY THE CITY OF THE ADEQUACY AND AVAILABILITY FOR WATER FOR PERSONAL USE AND FIRE PROTECTION WITHIN SUCH PLAT, AS REQUIRED UNDER ORDINANCE 83-54.

LEGEND	
IRF	IRON ROD FOUND
(C.M.)	CONTROLLING MONUMENT
P.O.B.	POINT OF BEGINNING
R.O.W.	RIGHT-OF-WAY
CAB.	CABINET
SL.	SLIDE
VOL.	VOLUME
PG.	PAGE
ESMT.	EASEMENT
P.R.R.C.T.	PLAT RECORDS, ROCKWALL COUNTY, TEXAS
D.R.R.C.T.	DEED RECORDS, ROCKWALL COUNTY, TEXAS
XF	"X" CUT IN CONCRETE FOUND
IRFC	IRON ROD WITH PLASTIC CAP FOUND

OWNER / DEVELOPER  
 ROCKWALL ECONOMIC  
 DEVELOPMENT CORPORATION  
 697 EAST INTERSTATE 30  
 P.O. BOX 968  
 ROCKWALL, TEXAS 75087  
 PHONE: (972) 772-0025

REPLAT  
 LOT 2R, BLOCK B  
 ROCKWALL TECHNOLOGY PARK  
 PHASE II  
 BEING A REPLAT OF LOT 2, BLOCK B, ROCKWALL TECHNOLOGY  
 PARK, PHASE II AS SHOWN BY THE PLAT RECORDED IN  
 CABINET I, SLIDES 113-115.  
 BEING 10.649 ACRES OF LAND LOCATED IN THE  
 JOHN H.B. JONES SURVEY, ABSTRACT NO. 125 &  
 JOHN A. RAMSEY SURVEY, ABSTRACT NO. 186  
 CITY OF ROCKWALL, ROCKWALL COUNTY, TEXAS  
 CASE NUMBER \_\_\_\_\_

VOTEX SURVEYING COMPANY - TBPLS FIRM NO. 10013600  
 10440 N. CENTRAL EXPWY, STE. 800 DALLAS, TEXAS 75231  
 PH. (469) 333-8831; candy@votexsurveying.com  
 PROJECT NO. 2022-018 SHEET 1 OF 2

**OWNER'S CERTIFICATION**

**STATE OF TEXAS  
COUNTY OF ROCKWALL**

**WHEREAS** ROCKWALL ECONOMIC DEVELOPMENT CORPORATION, BEING THE OWNER OF A TRACT OF land in the County of Rockwall, State of Texas, said tract being described as follows:

**BEING** a tract of land situated in the John H.B. Jones Survey, Abstract No. 125 and the John A. Ramsey Survey, Abstract No. 186, City of Rockwall, Rockwall County, Texas and being all of Lot 2, Block B, Rockwall Technology Park, Phase II, an addition to the City of Rockwall, Texas, according to the plat thereof recorded in Cabinet I, Slides 113-115, Plat Records, Rockwall County, Texas; same being a portion of that tract of land conveyed to Rockwall Economic Development Corporation by deed recorded in Volume 2224, Page 226, Deed Records, Rockwall County, Texas, and being more particularly described as follows:

**BEGINNING** at an "X" cut in concrete found at the intersection of the south right-of-way line of Discovery Boulevard (an 85-foot wide right-of-way) with the east right-of-way line of Corporate Crossing (a 110-foot wide right-of-way); same being the northwest corner of said Lot 2;

**THENCE** with said south right-of-way line of Discovery Boulevard, the following courses and distances:

N 83°29'08" E, a distance of 99.85 feet to an "X" cut in concrete found for an angle point;

N 89°11'46" E, a distance of 110.31 feet to a point for the beginning of a tangent curve to the left; from which a 1/2-inch iron rod found bears N 13°27'11" E, a distance of 0.35 feet;

In a northeasterly direction, with said curve to the left having a central angle of 24°18'47", a radius of 1042.50 feet, a chord that bears N 77°02'23" E, a distance of 439.06 feet and an arc length of 442.37 feet to a point for the common north corner of said Lot 2 and Lot 3, Block B of said Rockwall Technology Park, Phase II; from which a 1/2-inch iron rod with plastic cap stamped "WIER & ASSOC. INC." bears N 55°05'43" W, a distance of 0.31 feet;

**THENCE** S 01°24'22" E, departing said south line Discovery Boulevard and with the common line of said Lots 2 and 3, a distance of 799.25 feet to a 1/2-inch iron rod with plastic cap stamped "WIER & ASSOC. INC" found in the north right-of-way line of Springer Road (an 80-foot wide right-of-way) at the common south corner of said Lots 2 and 3;

**THENCE** S 88°35'38" W, with said north right-of-way line of Springer Road, a distance of 631.15 feet to a point for corner at the intersection of said north right-of-way line with said east right-of-way line of Corporate Crossing; from which a 1/2-inch iron rod with plastic cap stamped "WIER & ASSOC. INC" bears N 10°48'39" E, a distance of 0.17 feet;

**THENCE** N 02°07'14" W, with said east right-of-way line of Corporate Crossing, a distance of 703.63 feet to the **POINT OF BEGINNING** and containing 463,889 square feet or 10.649 acres of land, more or less.

**SURVEYOR'S STATEMENT**

NOW, THEREFORE KNOW ALL MEN BY THESE PRESENTS:

THAT I, Candy Hone, a Registered Professional Land Surveyor, licensed by the State of Texas, do hereby certify that I prepared this plat from an actual and accurate survey of the land, and that the corner monuments shown thereon were properly placed under my personal supervision.

Dated this the \_\_\_\_\_ day of \_\_\_\_\_, 2024.

**PRELIMINARY**

RELEASED 11/10/2024 FOR REVIEW PURPOSES ONLY. THIS DOCUMENT SHALL NOT BE RECORDED FOR ANY PURPOSE AND SHALL NOT BE USED OR VIEWED OR RELIED UPON AS A FINAL SURVEY DOCUMENT.

Candy Hone, Registered Professional Land Surveyor, No. 5867  
Votex Surveying Company - Firm No. 10013600 - (469) 333-8831

**STATE OF TEXAS §  
COUNTY OF DALLAS §**

Before me, the undersigned, a Notary Public in and for the County and State on this day personally appeared Candy Hone, known to me to be the person whose name is subscribed to the foregoing instrument and acknowledged to me that she executed the same for the purpose and consideration therein expressed and in the capacity therein stated.

GIVEN UNDER MY HAND AND SEAL OF OFFICE this the \_\_\_\_\_ of \_\_\_\_\_, 2024.

\_\_\_\_\_  
Notary Public, State of Texas

**NOW, THEREFORE, KNOW ALL MEN BY THESE PRESENTS:**

**STATE OF TEXAS  
COUNTY OF ROCKWALL**

I the undersigned owners of the land shown on this plat, and designated herein as the ROCKWALL TECHNOLOGY PARK, PHASE II subdivision to the City of Rockwall, Texas, and whose name is subscribed hereto, hereby dedicate to the use of the public forever all streets, alleys, parks, water courses, drains, easements and public places thereon shown on the purpose and consideration therein expressed. I further certify that all other parties who have a mortgage or lien interest in the ROCKWALL TECHNOLOGY PARK, PHASE II subdivision have been notified and signed this plat. I understand and do hereby reserve the easement strips shown on this plat for the purposes stated and for the mutual use and accommodation of all utilities desiring to use or using same. I also understand the following:

1. No buildings shall be constructed or placed upon, over, or across the utility easements as described herein.
2. Any public utility shall have the right to remove and keep removed all or part of any buildings, fences, trees, shrubs, or other growths or improvements which in any way endanger or interfere with construction, maintenance or efficiency of their respective system on any of these easement strips; and any public utility shall at all times have the right of ingress or egress to, from and upon the said easement strips for purpose of construction, reconstruction, inspecting, patrolling, maintaining, and either adding to or removing all or part of their respective system without the necessity of, at any time, procuring the permission of anyone.
3. The City of Rockwall will not be responsible for any claims of any nature resulting from or occasioned by the establishment of grade of streets in the subdivision.
4. The developer and subdivision engineer shall bear total responsibility for storm drain improvements.
5. The developer shall be responsible for the necessary facilities to provide drainage patterns and drainage controls such that properties within the drainage area are not adversely affected by storm drainage from the development.
6. No house dwelling unit, or other structure shall be constructed on any lot in this addition by the owner or any other person until the developer and/or owner has complied with all requirements of the Subdivision Regulations of the City of Rockwall regarding improvements with respect to the entire block on the street or streets on which property abuts, including the actual installation of streets with the required base and paving, curb and gutter, water and sewer, drainage structures, storm structures, storm sewers, and alleys, all according to the specifications of the City of Rockwall; or

Until an escrow deposit, sufficient to pay for the cost of such improvements, as determined by the city's engineer and/or city administrator, computed on a private commercial rate basis, has been made with the city secretary, accompanied by an agreement signed by the developer and/or owner, authorizing the city to make such improvements at prevailing private commercial rates, or have the same made by a contractor and pay for the same out of the escrow deposit, should the developer and/or owner fail or refuse to install the required improvements within the time stated in such written agreement, but in no case shall the City be obligated to make such improvements itself. Such deposit may be used by the owner and/or developer as progress payments as the work progresses in making such improvements by making certified requisitions to the city secretary, supported by evidence of work done; or

Until the developer and/or owner files a corporate surety bond with the city secretary in a sum equal to the cost of such improvements for the designated area, guaranteeing the installation thereof within the time stated in the bond, which time shall be fixed by the city council of the City of Rockwall.

I further acknowledge that the dedications and/or exaction's made herein are proportional to the impact of the Subdivision upon the public services required in order that the development will comport with the present and future growth needs of the City; I, my successors and assigns hereby waive any claim, damage, or cause of action that I may have as a result of the dedication of exactions made herein.

Witness our hands this the \_\_\_\_\_ Day of \_\_\_\_\_, 2024.

By: Rockwall Economic Development Corporation,  
a Texas nonprofit corporation

\_\_\_\_\_  
Name

**STATE OF TEXAS §  
COUNTY OF DALLAS §**

Before me, the undersigned authority, a Notary Public in and for the County and State on this day personally appeared \_\_\_\_\_, known to me to be the person and officer whose name is subscribed to the foregoing instrument, and acknowledged to me that he/she executed the same for the purpose and consideration therein and in the capacity therein stated.

GIVEN UNDER MY HAND AND SEAL OF OFFICE, this \_\_\_\_ day of \_\_\_\_\_, 2024.

\_\_\_\_\_  
Notary Public, State of Texas

\_\_\_\_\_  
Printed Name

**OWNER / DEVELOPER**  
ROCKWALL ECONOMIC  
DEVELOPMENT CORPORATION  
697 EAST INTERSTATE 30  
P.O. BOX 968  
ROCKWALL, TEXAS 75087  
PHONE: (972) 772-0025

**CITY SIGNATURES**

\_\_\_\_\_  
Planning & Zoning Commission, Chairman

\_\_\_\_\_  
Date

**APPROVED:**  
I hereby certify that the above and foregoing plat of an addition to the City of Rockwall, Texas, was approved by the City Council of the City of Rockwall on the \_\_\_\_\_ day of \_\_\_\_\_, 2024.

\_\_\_\_\_  
Mayor, City of Rockwall

\_\_\_\_\_  
City Secretary

\_\_\_\_\_  
City Engineer

**REPLAT  
LOT 2R, BLOCK B  
ROCKWALL TECHNOLOGY PARK  
PHASE II**

BEING A REPLAT OF LOT 2, BLOCK B, ROCKWALL TECHNOLOGY PARK, PHASE II AS SHOWN BY THE PLAT RECORDED IN CABINET I, SLIDES 113-115.

BEING 10.649 ACRES OF LAND LOCATED IN THE JOHN H.B. JONES SURVEY, ABSTRACT NO. 125 & JOHN A. RAMSEY SURVEY, ABSTRACT NO. 186 CITY OF ROCKWALL, ROCKWALL COUNTY, TEXAS  
CASE NUMBER \_\_\_\_\_

VOTEX SURVEYING COMPANY – TBPLS FIRM NO. 10013600  
10440 N. CENTRAL EXPWY, STE. 800 DALLAS, TEXAS 75231  
PH. (469) 333-8831; candy@votexsurveying.com  
PROJECT NO. 2022-018 SHEET 2 OF 2



City of Rockwall  
*The New Horizon*

## MEMORANDUM

---

**TO: Mary Smith, City Manager**

**FROM: Amy Williams, Director of Public Works/City Engineer**

**DATE: December 2, 2024**

**SUBJECT: Proposed 2025 Sanitary Sewer Condition Assessment**

---

The strategic plan associated with the City's Capacity, Management, Operations, and Maintenance (CMOM) Plan presented to the EPA requires the City to complete a condition assessment of the sewer system within ten years. To develop this strategic initiative, staff and the firm that worked on the CMOM took the information from the flow monitoring study conducted in the spring of 2015. The study was divided into 37 basins that were ranked depending on how much inflow and infiltration was detected in rain events.

The strategic initiative consists of a condition assessment of evaluating the basins that scored the lowest score in the study first. In 2024 - 2025, the wastewater division proposes to complete a condition assessment of three basins with a total of 116,155 feet of pipe with 425 manholes. The Professional Services Contract for the sanitary sewer condition assessment cost \$176,406.00. The funds are available in the water and sewer operating budget, sewer line repair and replacement. Assessments of these basins will include:

- Manhole inspections
- Smoke testing
- Dye flooding
- Cleaning (City)
- CCTV (City)
- Analysis of any defects
- Mapping
- Cost estimates for repair or rehab
- Data collecting
- Final report

Staff requests the City Council consider authorizing the City Manager to execute a contract with Pipeline Analysis LLC for the Sanitary Sewer Assessment in the amount of \$176,406.00 to be paid from the Water and Sewer Fund.

**Professional Services Contract**  
**City of Rockwall**  
**Year 8**  
**Sanitary Sewer Condition Assessment**  
**Flow Meter Basins**  
**SC16, SHORES2 and BC12A**



City of Rockwall  
*The New Horizon*

**November 19, 2024**



**PIPELINE ANALYSIS LLC**  
**1115 Main Street**  
**Garland, Texas 75040**  
**800-637-0164**  
**TBPE Firm No. F-6538**

## **CONTRACT FOR PROFESSIONAL ENGINEERING SERVICES**

THIS CONTRACT made and entered into on the date last stated below between the City of Rockwall, hereinafter called "City", and Pipeline Analysis, LLC hereinafter called "ENGINEER", acting by and through Mattie A. Engels, P.E. (Project Manager) duly authorized to so act on behalf of the ENGINEER.

WHEREAS, the CITY desires professional engineering services in connection with the Sanitary Sewer Condition Assessment of sewer on a specified portion of the City of Rockwall, Texas, hereinafter called "the PROJECT"; and

WHEREAS, the CITY has determined that the ENGINEER has experience in the area involved in the Project and is qualified to perform the work, and the ENGINEER is willing to enter into a contract with CITY to perform the engineering services desired by CITY in connection with the PROJECT.

THE CITY AND ENGINEER AGREE AS FOLLOWS:

The CITY hereby retains the ENGINEER to perform engineering services in connection with the PROJECT described above.

### **1. SCOPE OF SERVICES**

The scope of Professional Engineering Services to be performed by the ENGINEER shall be as follows:

#### **1.1 Approach to Project**

This project will perform various field testing and inspection of the wastewater collection system within the Study Area as defined on the map included in Exhibit A and prepare a final report that recommend system repairs and estimated costs.

#### **1.2 Detailed Scope of Services**

See Exhibit A attached.

### **2. CITY'S RESPONSIBILITIES**

So as not to delay the services of ENGINEER, the CITY shall do the following in a timely manner:

#### **2.1 Provide Existing Data**

CITY will provide to ENGINEER at no cost those sewer maps and any applicable previous reports. Existing data delivered to the ENGINEER by the CITY remains

the property of the CITY and must be returned to the CITY after completion of the PROJECT.

## **2.2 Provide Access**

Arrange for access to, and make all provisions for, ENGINEER to perform services under this AGREEMENT.

## **2.3 CITY Representative**

CITY designates the following person as the project representative to act as the contact person on behalf of the CITY.

Shon Bellah  
Water/ Wastewater Manager  
City of Rockwall  
1600 Airport Road  
Rockwall, TX 75087  
972.771.7730

## **2.4 Cleaning and CCTV Inspection**

CITY desires to perform the cleaning and CCTV inspection of sanitary sewers identified by Pipeline Analysis LLC. Pipeline Analysis LLC shall prepare a listing of line segments requiring internal cleaning and CCTV inspection based on field testing and inspection within the study areas. City will perform the cleaning and CCTV of the designated gravity sewers and provide Pipeline Analysis LLC the resulting database and digital video of the inspections. Pipeline Analysis LLC will incorporate these findings into the final report.

# **3. SCHEDULE**

## **3.1 Schedule**

The ENGINEER'S services shall be performed in a timely manner consistent with sound professional practices. The ENGINEER will complete the work according to the schedule presented in Exhibit A.

The time limits set forth in the schedule shall include allowances for reasonable and expected review time by the CITY and approval by authorities having jurisdiction over the PROJECT, and shall not be allowed as cause for delay or adjustments to the schedule. Delays in the project critical path caused by review times by the CITY or a permitting agency exceeding those anticipated by the ENGINEER'S schedule are cause for adjustments in the schedule. Any

adjustments made to the agreed upon schedule shall be made in writing and acceptable to both parties.

The ENGINEER shall begin work immediately upon receipt of the executed CONTRACT and/or written Notice to Proceed.

### **3.2 Completion of Services**

ENGINEER'S services under each item of the finalized Scope of Work shall be considered complete on the date when the submissions for that item have been accepted by CITY.

### **3.3 Changes**

If the CITY requests significant modifications or changes in the Scope of Services, general scope, extent or character of the PROJECT, the time of performance of ENGINEER'S services, the various rates of compensation and schedule shall be adjusted equitably.

### **3.4 Written Authorization for Additional Work**

Any provision in this CONTRACT notwithstanding, it is specifically understood and agreed that the ENGINEER shall not authorize or undertake any work pursuant to this CONTRACT which would require the payment of any fee, expense or reimbursement in addition to the fees stipulated in Section 4 (Payment for Services) of this CONTRACT, without first having obtained the specific written authority to do so from CITY.

## **4. PAYMENT FOR SERVICES**

### **4.1 Terms**

Terms used in describing the applicable method of payment for services provided by the ENGINEER shall have the meaning indicated below:

#### ***Basic Engineering Fee:***

Basic Engineering Fee shall mean those expenses incurred by the ENGINEER in prosecuting the PROJECT Scope of Services.

### ***Reimbursable Expenses***

Not applicable

### ***Additional Services***

Additional services **not** covered under the Scope of Services, will be provided to the CITY on a unit price or lump sum basis. A revised written detailed scope of services for additional services will be provided with the pricing summary. Additional services must be approved by City along with a written notice to proceed.

#### ***4.2 Basis and Amount of Compensation for Basic Services***

Compensation for basic services will be as shown in Exhibit A. These services will be billed monthly based on a percentage completed and will not exceed the total presented.

#### ***4.3 Basis and Amount of Compensation for Additional Services***

Not applicable. No additional services are anticipated.

#### ***4.4 Partial Payments for Services***

Partial fee payments may be applied for at monthly intervals, based upon statements which reflect the percentage of work completed for the various items listed under Scope of Services. These statements shall be prepared by the ENGINEER and must be verified and approved by CITY.

#### ***4.5 Delay***

If ENGINEER'S design services or service during construction of the PROJECT are delayed or suspended in whole or in part by the CITY for more than one year for reasons beyond ENGINEER'S control the various rates of compensation, including Additional Services, provided for elsewhere in this CONTRACT shall be subject to equitable adjustment.

## **5. TERMINATION, SUSPENSIONS OR ABANDONMENT**

### ***5.1 Termination***

The CITY or the ENGINEER may terminate this CONTRACT for reasons identified elsewhere in this CONTRACT. In the event such termination becomes necessary, the party effecting termination shall so notify the other party, and termination will



become effective thirty (30) calendar days after receipt of the termination notice. Irrespective of which party shall effect termination or the cause therefore, CITY shall within thirty (30) calendar days of termination remunerate ENGINEER for services rendered and costs incurred, in accordance with the ENGINEER'S prevailing fee schedule (Exhibit A). Services shall include those rendered up to the time of termination. All plans, field survey, and other data related to the PROJECT shall become the property of CITY upon termination of the CONTRACT and shall be promptly delivered to CITY in a reasonably organized form. Should CITY subsequently contract with a new Engineer for continuation of services on the PROJECT, ENGINEER shall cooperate in providing information. No amount shall be due for lost or anticipated profits.

### **5.2 Suspension**

If the Project is suspended by CITY for more than 30 consecutive days, the ENGINEER shall be compensated for services performed prior to notice of such suspension. When the Project is resumed, the ENGINEER'S compensation shall be equitably adjusted to provide for expenses incurred in the interruption and resumption of the ENGINEER'S services.

### **5.3 Abandonment**

This CONTRACT may be terminated by CITY upon not less than seven (7) days written notice to the ENGINEER in the event that the Project is permanently abandoned. If the Project is abandoned by CITY for more than ninety (90) consecutive days, the ENGINEER or CITY may terminate this CONTRACT by giving written notice.

### **5.4 Failure to Pay**

Failure of CITY to make payments to the ENGINEER in accordance with this CONTRACT shall be considered substantial nonperformance and cause for termination.

If CITY fails to make payment to ENGINEER within thirty (30) days of a statement for services properly performed, the ENGINEER may, upon fourteen (14) days written notice to CITY, suspend performance of services under this CONTRACT. Unless ENGINEER receives payment in full within fourteen (14) days of the date of the notice, the suspension shall take effect without further notice. In the event of a suspension of services under this section, the ENGINEER shall have no liability to CITY for delay or damage caused CITY because of such suspension of services.

**6. GENERAL CONSIDERATIONS**

**6.1 Professional Standards**

Services performed by the ENGINEER under this CONTRACT will be conducted in a manner consistent with that level of care and skill ordinarily exercised by members of the profession currently practicing in the same locality under similar conditions. The ENGINEER shall comply with the applicable laws and rules of the current "Texas Engineering Practice Act". CITY's approval, acceptance, use of or payment for all or any part of the ENGINEER'S services herein under or of the project itself shall in no way alter the ENGINEER'S obligations or CITY'S rights thereunder.

**6.2 Progress and Performance**

The provisions of this CONTRACT and the compensation to ENGINEER have been agreed to in anticipation of continuous and orderly progress through the completion of the ENGINEER'S services. Time for performance shall be extended to the extent necessary for delays due to circumstances over which the ENGINEER has no control. If the ENGINEER'S services are suspended or delayed the times of performance shall be extended to the extent of such delay or suspension. A delay or suspension shall not terminate this CONTRACT unless ENGINEER elects to terminate in accordance with the provisions of Section 5 of this CONTRACT. If a delay or suspension extends for a period of greater than one year for reasons beyond the control of the ENGINEER, the fees and rates of compensation set forth in Section 4 shall be subject to re-negotiating.

**6.3 CITY Control**

It is understood and agreed that CITY shall have complete control of the services to be rendered, and that no work shall be done under this CONTRACT until the ENGINEER is instructed to proceed with the work.

**6.4 Independent Agent**

ENGINEER and CITY agreed that ENGINEER and any officer, employee or agent of ENGINEER, in the performance of this CONTRACT shall act in an independent capacity and not as an officer, agent or employee of CITY.

**6.5 Compliance with Laws**

ENGINEER shall comply with all Federal, State, and local laws and ordinances in the execution of all work in connection with this PROJECT.

### **6.6 No Additional Work Without Authorization**

Any provision in the CONTRACT notwithstanding, it is specifically understood and agreed that the ENGINEER shall not authorize or undertake any work pursuant to this CONTRACT, which would require the payment of any fee, expense or reimbursement in addition to the fee stipulated in Article 4 of this CONTRACT, without having first obtained specific written authority therefore from CITY.

### **6.7 Assignment & Subcontracting**

This CONTRACT shall not be assigned or subcontracted in whole or part without the written consent of CITY.

### **6.8 Indemnification**

ENGINEER, its officers, agents and employees agree to indemnify, hold harmless, and defend CITY, at ENGINEER'S cost, its officers, agents, and employees from and against any and all claims or suits for injuries, damages, loss, or liability of whatever kind of character, arising out of or in connection with the performance by the ENGINEER of those services contemplated by the CONTRACT, based upon negligent acts or omissions of ENGINEER, its officers, agents, employees, consultants and subcontractors, whether or not caused solely by the ENGINEER, its officers, agents, employees, consultants or subcontractors or jointly with any other party.

ENGINEER agrees that he is solely responsible for the safety of himself and his employees in the performance of this CONTRACT and agrees to indemnify and hold harmless CITY, its officers and agents from and against any liability arising from the personal injury or death of the ENGINEER or the employees of the ENGINEER arising out of or in connection with this CONTRACT.

### **6.9 Insurance**

ENGINEER shall secure and maintain insurance that will protect him from claims under the Worker's Compensation Act (statutory amounts).

ENGINEER shall secure and maintain Commercial General Liability Insurance that will protect him from claims for bodily injury, death or property damage which may arise from the performance of his services under this CONTRACT, written on an occurrence basis, in the following amounts:

For engineering design contracts for more than \$10,000.00, insurance in an amount not less than \$500,000 per occurrence and \$1,000,000 annual aggregate for bodily injury or death and property damage. ENGINEER shall maintain Comprehensive Automobile Liability Insurance covering all owned, non-owned, and hired

vehicles with combined single limit coverage of \$1,000,000 for bodily injury, death or property damage.

ENGINEER shall maintain, at no expense to CITY, a professional liability (errors and omissions) insurance policy placed with a company rated at least A-/VII by Best's Key Rating Guide, authorized to do business in Texas. This coverage must be maintained for at least two (2) years after the PROJECT is completed. Coverage must be written on an occurrence basis. However, at its sole discretion, the CITY may accept coverage written on a claims-made basis if the policy provides for a retroactive date equivalent to the inception date of the CONTRACT or earlier, maintained during the full term of the CONTRACT. The minimum limits of coverage shall be in the following amounts:

All policies, except Worker's Compensation and Professional Liability, shall name the CITY as additional insured. All policies shall contain a waiver of subrogation in favor of the CITY and shall require the giving of written notice to CITY at least thirty (30) days prior to cancellation, non-renewal or material modification of any policies, evidenced by return receipt of United States Certified Mail. ENGINEER shall furnish CITY with copies of said policies or certificates evidencing such coverage.

#### **6.10 Property**

All documents, including drawings, field notes, surveys, tracings, calculations, computer input and output, digital or computer files, etc., prepared by the ENGINEER pursuant to this contract shall become the property of CITY. The ENGINEER may retain copies of all documents. Any reuse of the documents shall conform to The Texas Engineering Practice Act.

#### **6.11 Governing Law**

This CONTRACT has been made under and shall be governed by the laws of the State of Texas. The parties agree that the performance and all matters related thereto shall be in Rockwall, Texas.

**7. DOCUMENT EXECUTION**

IN WITNESS WHEREOF, the parties have executed this CONTRACT the \_\_\_\_\_ day of \_\_\_\_\_, 2024.

**City of Rockwall, Texas  
Rockwall City Hall  
385 South Goliad  
Rockwall, Texas 75087**

By: \_\_\_\_\_

Date: \_\_\_\_\_

**ENGINEER  
Pipeline Analysis, LLC  
1115 Main Street  
Garland, Texas 75040  
(800) 637-0164**

By: Mattie A. Engels  
Mattie A. Engels, P.E. (Vice-President)

Date: November 19, 2024

# Exhibit A

## Detailed Scope of Services

The purpose of this project is to perform a condition assessment on a portion of the City of Rockwall wastewater collection system and identify system defects that contribute to wet weather infiltration/inflow. The following summarizes the project tasks and approach to the project:

### TASK 100 MOBILIZATION

Mobilize project team and coordinate startup. Establish personnel assignments and responsibilities. Inventory equipment needs and order expendable supplies. Review all relevant existing materials, previous reports, etc. developed for or by the City of Rockwall.

#### *Deliverable:*

1. Delivery of equipment and personnel
2. Work maps with delineated boundaries

#### *To Be Provided by City:*

1. Previous studies for the service area to be investigated
2. Sewer maps
3. Previous inspection data, where available
4. Access for placement of equipment and personnel
5. Copies of all applicable reports, maps and historical data for the study area at no cost to ENGINEER
6. As-built drawings, sewer key maps, street plans, electronic aerial photographs if available and if requested at no cost to ENGINEER

### TASK 200 MANHOLE/PIPE INSPECTION

Manholes can be a significant source of extraneous infiltration/inflow and thereby reduce system wet weather capacity. For this reason, each manhole within the study area is inspected. For the study area designated, field inspection crews will perform an inspection of manholes. The data gathered during this phase of the project will be used to prioritize manholes for rehabilitation and establish the base data necessary to accurately determine mainline sewer rehabilitation alternatives and costs. Other important deliverables resulting from this work task are the updating of the collection system map, determination of debris levels in pipes and verification of pipe sizes. This information is critical in preparing subsequent rehabilitation plans, cleaning requirements to restore capacity and updating of the system maps.

Inspection personnel will use digital cameras during the inspection of all manholes on this project. All photographs will be included in the field inspection computer database so that a permanent electronic record can be maintained. During inspection, each of the following types of information will be obtained to establish the condition and prioritize least cost repairs:

1. Study Area Designation
2. Manhole/Cleanout ID
3. Inspection Status (buried, could not locate, no access, etc.)
4. Address and Sub-meter GPS coordinate (x,y) of manhole
5. Surface cover, grade, type of cover (paved, yard, etc.)
6. Material of construction – brick, concrete, etc.
7. Area and Internal photo of manhole
8. All incoming and outgoing pipe depths from rim to invert
9. All incoming and outgoing pipe digital photographs
10. Outgoing pipe length
11. Defects – Active, Evidence or No Infiltration/Inflow with digital photographs
12. Field corrections to collection system map

Upon completion of the manhole inspection, a condition assessment will be prepared for inclusion in the final report that will include:

1. Documentation with summary of field observations
2. List of manholes/lines requiring repair/rehabilitation
3. Digital photos
4. Documentation for preparing manhole rehabilitation quantities
5. Field updated map(s)
6. Prioritized Manhole Repair Recommendations and Cost Estimates

*To Be Provided by City:*

1. Current collection system map
2. Access (if requested) to manholes that are buried or could not be opened.
3. Assistance in locating assets (if requested)

*Measurement of Payment:*

Payment for this work task shall be a unit price for each manhole documented. Those manholes that are located, but buried or could not be opened will be noted and a list provided to the City. Manholes that could not be located using metal detectors or probes will be listed as Could Not Located (CNL). CNL manholes will not be billed. The City will provide replacement covers at no cost should a cover be broken while attempting opening.

## TASK 300 SMOKE TESTING/PUBLIC AWARENESS/DATA ENTRY & ANALYSIS

Smoke testing will provide detailed information on wet weather inflow sources for the study area. In order to identify defects in the lines, a non-toxic smoke will be forced into the sewer by high-capacity blowers. Data documentation includes measurements from two permanent points and will be sufficient to establish the location of each defect and determine the best repair method and priority. Color digital photographs will be taken to document each defect during the smoke test.

Forty-eight (48) hours prior to testing, door hangers will be used to notify residents. A local telephone number will be provided for those individuals with questions or for anyone requiring special assistance. Each day the fire department will be notified of the crew location since smoke may enter homes through defective plumbing.

### *To Be Provided by City:*

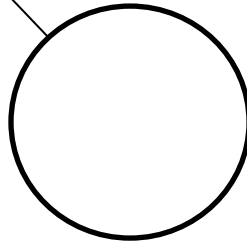
1. Review and approval of Notice to Residents
2. Letter of introduction to be carried by field crews
3. Previous City smoke testing data, if any

### *Deliverables:*

1. Defects listing and database
2. Defect location sketch
3. Digital photographs
4. Smoke Notification Flyers and Notification of Residents
5. Priority ranking of defects (both private and public sector)
6. Repair methods and estimated costs



**Review  
Draft**



City of Rockwall  
*The New Horizon*

## **SMOKE TESTING NOTICE TO RESIDENT**

For the next few days, inspection crews will conduct a physical survey of the wastewater collection system. Pipeline Analysis will perform this study, which involves opening manholes in the streets and backyard utility easements. Information gained from this study will be used to repair and improve the wastewater collection system.

One important task of the survey will be **smoke testing** of sewer lines to locate breaks and defects in the system. During this testing, white smoke will exit through vent pipes on the roofs of homes and through sewer line breaks. **The smoke is non-toxic, leaves no residue, and creates no fire hazard.** The smoke should not enter your home unless defective plumbing exists or drain traps are dry.

If you have seldom-used drains, please pour a gallon of water in the drain to fill the drain trap. This procedure will help prevent the possibility of smoke entering your living areas through those drains.

Field crews will perform testing of all sewers in the area. **At no time will field crews have to enter your business or residence.**

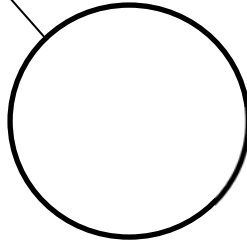
Your cooperation is appreciated. Should you have any additional questions concerning this study or if you desire special assistance, please phone:

**800-637-0164**



QR Code for frequently  
asked questions

**Review  
Draft**



City of Rockwall  
*The New Horizon*

## **PRUEBAS DE HUMO AVISO A LOS RESIDENTES**

Para los próximos días, los equipos de inspección llevará a cabo una inspección física de la red de alcantarillado. El Análisis de Pipeline Company, LLC llevará a cabo este estudio bajo contrato con la ciudad de Rockwall. El proyecto consiste en la apertura de pozos en las calles y servidumbres domésticas de servicios públicos. La información obtenida de este estudio se utilizarán para reparar y mejorar el sistema de recolección de aguas residuales.

Una tarea importante de la encuesta serán las pruebas de humo de líneas de alcantarillado para localizar roturas y defectos en el sistema. Durante esta prueba, el humo blanco saldrá a través de tubos de ventilación en los techos de las casas y por medio de saltos de línea de alcantarillado. El humo no es tóxico, no deja ningún residuo, y no crea ningún peligro de incendio. El humo no debe entrar a su casa a menos que exista o plomería defectuosa sifones están secos.

Si ha utilizado muy pocas veces-piso, lavabo, bañera o ducha desagües, por favor, vierta un litro de agua en el desagüe para llenar el sifón. Este procedimiento le ayudará a prevenir la posibilidad de humo introducción de sus áreas vivas a través de los desagües.

El personal de campo se realizan pruebas de todos los desagües de la zona. En ningún momento desplegar los equipos tiene que introducir su negocio o residencia.

Su cooperación es apreciada. Si tiene alguna pregunta adicional sobre este estudio o si desea recibir asistencia especial, por favor llame al:

**800-637-0164**



QR Code for frequently  
asked questions

## Task 400      Dye Flooding

Pipeline Analysis staff will provide a listing of recommended location(s) for dye water flooding. Dye water flooding can be anticipated to assist in the locating of specific defects during CCTV inspection of specific defects. Non-toxic dye may be introduced as a powder or liquid. Cross-connections, roof drains and area drains that are suspected of being connected to the sanitary sewer may be positively identified using the dye tracer procedure. Internal CCTV inspection, while the dye flooding is taking place, will determine the exact source of the 'cross-connection'.

### *To Be Provided by City:*

1. Cleaning and CCTV crew
2. Water for dye flooding
3. Coordination with Pipeline Analysis

### *To Be Provided by Pipeline Analysis:*

1. Locations for dye water flooding
2. Liquid or powder dye for use by the City
3. Field Forms to be used to document results
4. Documentation of results

## TASK 500 & 600 PREPARATORY CLEANING AND CCTV INSPECTION

Task 500 and 600 will be performed by City crews. Pipeline Analysis staff will prepare a detailed listing of line segments recommended for cleaning and CCTV inspection. Preparatory cleaning shall consist of hydraulic jet cleaning to facilitate the internal CCTV inspection. The City of Rockwall staff will perform this phase of the work in coordination with Pipeline Analysis.

### *To Be Provided by City:*

1. Preparatory cleaning of CCTV pipe segments
2. CCTV inspection of recommended pipe segments
3. Provide CCTV video including:
  - a. Date inspected
  - b. Line segment inspected
  - c. Location (Address) and Asset ID
  - d. Digital video of inspection and written logs of work performed

### *To Be Provided by Pipeline Analysis:*

1. Review video and logs not to exceed 15% of study area linear footage
2. Summary of line segments cleaned and CCTV'd
3. Prepare prioritized mainline rehabilitation plan and estimated costs
4. Incorporate Cleaning and CCTV inspection results into final report

## TASK 700 ADMINISTRATION AND PROJECT MANAGEMENT

This task includes internal project administration and oversight including scheduling, budget, quality assurance and control meetings and reporting. The project schedule will be reviewed and milestones for the completion of each task will be assigned. The project schedule will be reviewed and updated monthly to ensure that all tasks are completed in a timely and organized fashion.

Management work items include:

1. Field crew supervision and project planning
2. Obtain initial maps for field use and verification
3. Prepare cleaning, CCTV and dye flooding documentation for City
4. Prepare monthly billings
5. Schedule equipment and order supplies

Major system deficiencies that are identified during the field inspections that if corrected would result in significant reduction in I/I or is deemed to be of a safety concern will be recorded and forwarded as soon as possible to City's designated project manager. Likewise, should City undertake a major repair within the study area, they will immediately notify ENGINEER to determine the impact on data analysis.

*Deliverables:*

1. Monthly invoice
2. Status reports
3. Project schedule and updates

*To Be Provided by City:*

1. All reports or materials deemed necessary by ENGINEER and identified during the course of the project that is not specifically stated above will be provided at no additional cost to the ENGINEER

## TASK 800 DEFECT ANALYSIS/ REHABILITATION PLAN/FINAL REPORT

This project will generate a considerable amount of data that will require proper entry and quality control. Data collection will include the following:

1. All collected defect data will be correlated between sources to address duplicate defects that were identified by different testing methods. Identify duplicate defects to ensure multiple rehabilitation methods are not recommended for the same defect.
2. Much of the baseline data required for rehabilitation decision is gathered during the normal course of field investigations. For example, "area photos" are taken of each manhole in the direction of the outgoing pipe. This photograph not only shows the location of the manhole but also provide data on the line cover and easement conditions.
3. Rehabilitation recommendations will consider the best repair for the particular asset (manhole, pipeline, etc.) being rehabilitated. A long-term least-cost solution may have an initial higher cost, but provide a higher level of service and lower operating and maintenance cost. The supporting data will be provided in electronic format.

### *To Be Provided by City:*

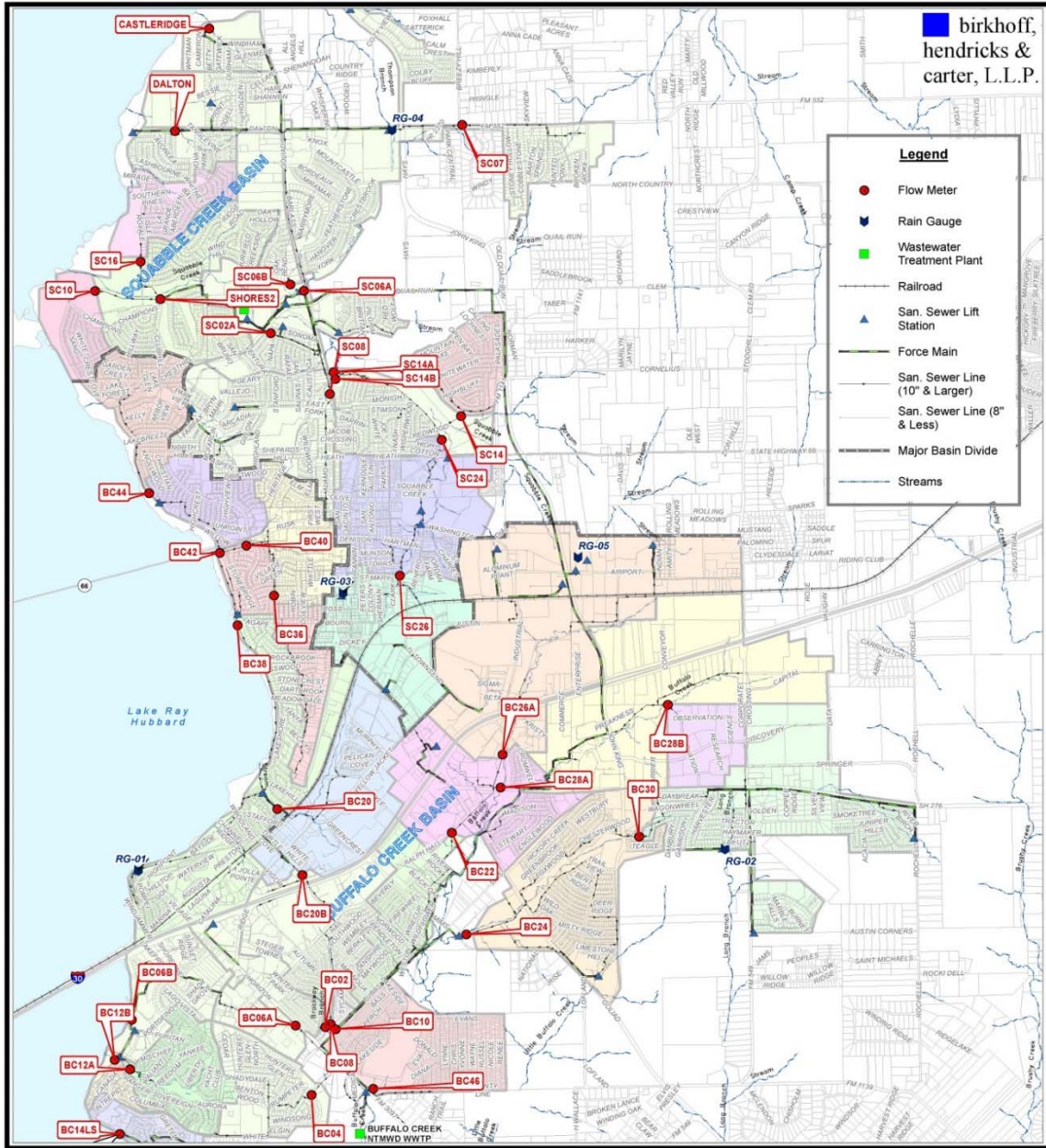
- Complaint records and SSO database
- Review and comments on rehabilitation methods, cost estimates, and alternatives
- Engineer will provide electronic files of the City corrected GIS maps in ArcGIS. The City will have the final authority to accept the changes and update their master GIS map files.

Prepare and submit a Final Report that includes the following:

- Executive Summary
- Description of all tasks
- Manhole and pipe inspection summary/inventory
- Manhole defect summary
- Pipeline defect summary
- Service lateral defect summary
- Smoke test data summary
- Dye Flooding and CCTV data summary
- Recommendations and Cost Estimates for Private and Public sector repairs

Prepare and submit three (3) Final Reports and electronic database.

# Study Area Map Flow Meter Basins SC16, SHORES2 and BC12A



**birkhoff,  
hendricks &  
carter, L.L.P.**

**Legend**

- Flow Meter
- Rain Gauge
- Wastewater Treatment Plant
- Railroad
- San. Sewer Lift Station
- Force Main
- San. Sewer Line (10" & Larger)
- San. Sewer Line (8" & Less)
- Major Basin Divide
- Streams

0 2,000 4,000  
Feet

**City of Rockwall**  
**2015 WASTEWATER FLOW MONITORING STUDY**

**Flow Meter  
& Rain Gauge  
Overview Map**

C:\Projects\Rockwall\2015113 WW Flow Monitoring\Report Figures.mxd

# Condition Assessment Priority Ranking



City of Rockwall

10 Year Condition Assessment CMOM Program  
Priority Ranking of Meter Basins



2015 Wastewater Flow Monitoring Study - Birkhoff, Hendricks & Carter, LLP

Completed  
Proposed

Meter Basin	RDII (mg)	Pipe (l.f.)	Manholes	RDII/Linear Foot	RDII Ranking	2017	2018	2019	2020	2021	2022	2023	2024	2025	2026	2027
SC26	0.51	21,915	66	23.27	1	21,915										
BC20B	1.76	119,423	362	14.74	2			119,423								
BC06A	0.33	22,548	232	14.64	3		22,548									
SC06B	0.11	8,527	26	12.90	4		8,527									
BC10	0.49	42,097	128	11.64	5		42,097									
BC08	0.48	45,259	137	10.61	6				45,259							
BC46	0.50	48,992	148	10.21	7				48,992							
BC38	0.39	39,947	121	9.76	8				39,947							
BC42	0.25	26,060	79	9.59	9		26,060									
SC08	0.46	48,248	146	9.53	10					48,248						
SC14AB	0.31	33,192	101	9.34	11					33,192						
SC24	0.37	45,123	137	8.20	12					45,123						
BC28A	0.22	30,660	155	8.11	13						30,660					
BC28B	0.06	7,920	23	7.58	14						7,920					
SC14	0.11	23,095	80	7.47	15						23,095					
BC04	0.18	24,645	80	7.41	16						24,645					
BC40	0.22	28,400	110	7.14	17						28,400					
BC20	0.15	33,920	132	6.59	18							33,920				
BC44	0.21	31,705	108	6.40	19							31,705				
SC02A	0.31	33,820	135	6.33	20							33,820				
BC02	0.12	15,760	58	6.17	21							15,760				
SC10	0.06	10,535	33	5.37	22								10,535			
BC26A	0.29	49,005	156	4.87	23								49,005			
BC30	0.31	53,190	185	4.25	24								53,190			
SC16	0.08	19,700	71	3.94	25									19,700		
BC12B	0.05	8,690	46	3.76	26										8,690	
SHORES2	0.20	57,570	176	3.62	27										57,570	
BC12A	0.16	38,885	175	3.46	28										38,885	
BC24	0.16	51,315	157	3.06	29											51,315
BC06B	0.06	19,900	100	2.98	30											19,900
BC14	0.10	20,925	85	2.93	31											20,925
DALTON	0.05	14,180	58	2.89	32											14,180
BC22	0.11	39,755	159	2.44	33											39,755
SC06A	0.10	62,130	199	2.31	34											62,130
BC36	0.05	22,340	68	2.24	35											22,340
SC07	0.05	22,860	71	2.15	36											22,860
CASTLERIDGE	0.02	11,155	34	1.73	37											11,155
<b>Total</b>		<b>1,233,389</b>	<b>4,337</b>			<b>21,915</b>	<b>99,232</b>	<b>119,423</b>	<b>134,198</b>	<b>126,561</b>	<b>114,720</b>	<b>115,205</b>	<b>112,730</b>	<b>116,155</b>	<b>126,165</b>	<b>147,085</b>

## Study Area Quantities

425 Manholes  
116,155 Linear Feet Mainline

# Compensation Sewer System Evaluation Survey

## Year 8 Basins SC16, SHORES2, BC12A

Task	Description	Estimated Quantity	Unit Price	Total
100	Mobilization	L.S.	L.S.	\$ 1,970.00
200	Manhole/Pipe Inspection -(100%)	425	\$ 150.00	\$ 63,750.00
300	Smoke Testing, Public Awareness, Data Entry & Analysis (100%)	116,155	\$ 0.68	\$ 78,985.40
400*	Dye Flooding	0	\$ 275.00	\$ -
500*	Preparatory Cleaning	0	\$ -	\$ -
600*	CCTV Inspection	0	\$ -	\$ -
700	Admin.,Project Mgt.	L.S.	L.S.	\$ 4,335.00
800	Defect Analysis/Rehab.	L.S.	L.S.	\$ 5,005.00
900	Database, Cost Estimates, Mapping, Final Reports	L.S.	L.S.	\$ 22,360.00
<b>Total Not To Exceed (City performs Dye Testing, Cleaning &amp; CCTV)</b>				<b>\$ 176,405.40</b>

# Project Schedule Sewer System Evaluation Survey

Task	Description	Month									
		1	2	3	4	5	6	7	8	9	10
100	Mobilization										
200	Manhole/Pipe Inspection -(100%)										
300	Smoke Testing, Public Awareness, Data Entry & Analysis (100%)										
400*	Dye Flooding										
500*	Preparatory Cleaning										
600*	CCTV Inspection										
700	Admin.,Project Mgt.										
800	Defect Analysis/Rehab.										
900	Database, Cost Estimates, Mapping, Final Reports										

\*Note: By City of Rockwall





## CITY OF ROCKWALL, TEXAS MEMORANDUM

---

**TO:** Mary Smith, City Manager  
Joey Boyd, Assistant City Manager  
Misty Farris, Purchasing Agent

**FROM:** Travis E. Sales, Director Parks, Recreation and Animal Services

**DATE:** December 2, 2024

**SUBJECT:** Yellow Jacket (1-3) and Myers (1-2) infield renovation

---

This project is for the laser leveling of infields, adding infield clay and infield equipment for five athletic fields. This will improve drainage, reduce rainouts and improve fields for player safety. The total budget for this project is \$100,000.00 to be funded out of the Recreation Development Fund. This is an approved 2024-2025 budget request.

The successful best value proposal was provided by United Turf and Track

Quote #1: Sports Field Solutions \$207,034.00 sealed bid  
Quote #2: United Turf and Track \$114,200.00 sealed bid

Sealed bids/proposals were opened on November 25, 2024 at 2:00pm and the City has met all formal bidding requirements pertaining to the renovation of athletic fields project. Park and Recreation staff will reduce clay quantities to keep us within budget.

For Council consideration is this Yellow Jacket and Harry Myers athletic field project award to the United Turf and Track for an amount not to exceed \$100,000.00 and authorize the City Manager to execute purchase orders and/or contracts for this project.



City of Rockwall  
*The New Horizon*

## MEMORANDUM

---

**TO: Rockwall City Council**

**FROM: Joey Boyd, Assistant City Manager**

**DATE: November 26, 2024**

**SUBJECT: Fire Station 2 Repairs**

---

On the evening of November 3, 2024, a motorist ran into Fire Station 2 at a high rate of speed and caused significant exterior and interior damage to the southwest corner of the building. The structural integrity of the building was not compromised but the crash left damage to the brick, destroyed multiple doors, and also requires replacement of framing, windows, and flooring. The City has filed a claim with the driver's insurance company and they have approved an initial reimbursement of \$78,078.76 based on the proposal by the City's contractor.

City Council is asked to consider approval of a total project budget of \$100,000, \$78,078.76 to Custard Construction Services for repairs to Fire Station 2 and the remainder as project contingency for unforeseen issues that may come to light once the repairs begin.

City Council is also asked to consider authorizing the city manager to execute an agreement with Custard Construction Services, and to amend the FY 25 Internal Operations Department operating budget, increasing it by \$100,000, which will be reimbursed from insurance proceeds.



City of Rockwall  
*The New Horizon*

## MEMORANDUM

---

**TO:** Mayor and Council Members

**FROM:** Hotel Occupancy Tax Sub-Committee Members  
Mary Smith, City Manager

**DATE:** November 26, 2024

**SUBJECT:** Supplemental Request – Amerisports

---

Amerisports Rockwall hosts basketball, volleyball, and cheer tournaments in their facility on Fit Sport Drive at Corporate Crossing. They have requested HOT funding to further their efforts to promote bringing tournaments to the Rockwall. The subcommittee met with the owners of the facility recently. After careful consideration the sub-committee has recommended a significantly lower amount than originally requested. As this is a new business venture the sub-committee felt that early funding should be limited as the business gets more familiar with appropriate uses of the funds.

Prior to Council action on the above, the Hotel Occupancy Tax budget is as follows:

Fund Balance carried forward	\$3,470,000
Budgeted Revenues	2,000,000
Previously Allocated Funding	<u>(1,310,900)</u>
Projected Fund Balance	\$4,159,100

Subcommittee members Campbell, Lewis, and McCallum recommend funding \$50,000 at this time. Council is asked to consider approving the funds as recommended by the subcommittee and authorizing the City Manager to execute the agreement with the organization.



**City of Rockwall**  
*The New Horizon*

# Hotel Occupancy Tax

## Program Year 2025

Events held Oct. 1, 2024 - Sept. 30, 2025

## Application

MUST BE TYPED or PRINTED

Deliver to:

City of Rockwall Finance Office

Attn: Misty Farris

385 S. Goliad St., Rockwall, TX 75087

Ph. 972-771-7700 Fax 972-771-7728 [mfarris@rockwall.com](mailto:mfarris@rockwall.com)

**Organization Name:** AmeriSports  
**Name of Event:** Various Events  
**Date(s) of Event:** Various  
**Funding Request \$:** \$520,000  
**Website Address:** www.amerisports.net  
**Mailing Address:** 3101 Fit Sport Life Blvd / Rockwall TX / 75032  
**Physical Address:** 3101 Fit Sport Life Blvd / Rockwall TX / 75032  
**Telephone:** 469-698-4848 Fax: xxxxx

**Primary Contact Name:** Patrick James  
 (Owner / Event Sponsor)  
**Mailing Address:** 3101 Fit Sport Life Blvd  
 Rockwall, TX 75032  
**Email Address:** patrick@amerisports.net  
**Telephone:** 469-261-5803 Fax: xxxx

**Secondary Contact Name:** Brad Steveson  
 (Owner / Event Director)  
**Mailing Address:** 3101 Fit Sport Life Blvd  
 Rockwall, TX 75032  
**Email Address:** brad@ameriSPorts.net  
**Telephone:** 615-509-0101 Fax: xxxx

- ▶ COMPLETE AN APPLICATION FOR EACH EVENT/PROGRAM/EXHIBIT REQUESTING FUNDS
- ▶ INCOMPLETE APPLICATIONS WILL NOT BE FORWARDED TO THE COUNCIL SUBCOMMITTEE

1. Mark an "X" next to the category or categories that your organization is requesting funds in the attached budget request.

**Advertising/Tourism**      **Requested funding amount \$ 520,000**  
Conducting solicitation or promotional programs that encourage tourists and delegates to come to the City of Rockwall.

**Arts**      **Requested funding amount \$**  
Providing encouragement, promotion, improvement and application of the arts as it relates to the presentation, performance execution or exhibition of the major art forms in the City of Rockwall.

**Historical**      **Requested funding amount \$**  
Providing historical restoration, preservation, programs and encouragement to visit preserved historic sites or museums located in the City of Rockwall.

2. Describe the program or event for the upcoming fiscal year (Oct. 1, 2024 – Sept. 30, 2025) that you are requesting Hotel Tax funding. What is your event and why are you having it?

AmeriSports has planned 28 regional and national sporting events for the 2025 program year (October 1, 2024 – September 30, 2025). These events typically include tournaments where teams from both within Texas and outside the state travel to participate. While we have 28 events currently scheduled, we expect to add an additional 10 to 15 events during the program year. Please note that only the events currently scheduled have been submitted at this time.

Each of the 28 scheduled events is a sporting tournament style event and include the following characteristics:

- 12 events are repeat / 16 events are new
- 24 events are basketball / 4 are volleyball
- 5 are three-day events (Friday-Sunday)
- 15 are two-day events (Saturday-Sunday)
- 8 are one-day events (Saturday or Sunday)
- Typical Event Schedules
  - Friday 5pm till 11pm
  - Saturday 8am till 11pm
  - Sunday 8am till 6pm

3. How does the event/program meet the definition of the categories listed in Item No. 1 above (promotion of tourism and the hotel industry in the City of Rockwall)?

AmeriSports actively supports the convention and hotel industries by promoting "play and stay" sporting tournaments. Our events encourage participants to stay overnight, and we direct them to our hotel partners for their accommodations, thereby enhancing both the sporting experience and the local hospitality sector.

4. Is the event/program that the organization is requesting Hotel Tax funds held in/on City-owned property?

Yes - Name location: AmeriSports / 3101 Fit Sport Life Blvd, Rockwall TX 75032

- Will your organization provide special event insurance coverage for the event/program if held on City property?

Yes - Name of Insurance Company: Philadelphia Insurance Companies

- Provide 3 years attendance history for the above listed programs, activities, exhibits or event described in Item No. 2 above.

Previous Year - July 15, 2024 through August 4, 2024				
Event	Year	Event Duration (in Days)	Audience Size	# of Attendees in hotel rooms
Cheer Combine	2024	2	4,500	1,350
Smash Cancer	2024	2	240	-
Hoopfest	2024	2	1,085	168
Season Opener	2024	3	2,431	2,044
MLK Super Showcase	2024	2	673	104
Rockwall Rumble	2024	2	1,889	687
Love & Basketball	2024	2	1,122	428
Texas Battle	2024	1	1,403	255
Pass The Ball	2024	2	1,122	448
Chamber Annual Banquet	2024	1	1,000	-
10K Invitational	2024	3	1,739	1,126
Girl Power	2024	1	1,403	255
Jr EYBL	2024	3	1,870	933
Battle for Texas	2024	2	1,403	560
Texas Smoke Feast	2024	2	1,403	560
Giveback	2024	3	1,720	1,017
Southwest Exposure Showcase	2024	3	2,057	1,027
5k Invitational	2024	3	1,870	1,190
Elite Mega Camps	2024	3	3,000	1,125
The Finale	2024	3	2,655	2,316
Hope Is Alive	2024	1	80	-
<b>Totals</b>		<b>46</b>	<b>34,663</b>	<b>15,594</b>

Upcoming Year - October 5, 2024 through August 3, 2025				
Event	Year	Event Duration (in Days)	Audience Size	# of Attendees in hotel rooms
Best of the Best Futures	2024	1	2,244	448
Made Hoops Tournament 1	2024	2	2,244	896
Hoops for a Cure	2024	2	935	373
Basketball Camp	2024	2	2,244	1,020
Hoopfest	2024	2	1,496	231
The Season Opener	2024	3	2,618	2,231
BlockSports 1	2024	2	1,496	544
DFW Elite	2024	1	1,122	224
MLK Super Showcase	2024	2	1,496	231
Slam 1	2024	1	1,122	224
Slam 2	2024	1	1,122	224
Love & Basketball	2024	2	1,496	571
Heart of City	2024	2	1,496	597
Rockwall Rumble	2024	2	1,870	680
Made Hoops Tournament 2	2024	2	1,496	597
Made Hoops Tournament 3	2024	2	1,496	597
BlockSports	2024	2	1,496	544
10K Invitational	2024	3	1,870	1,211
Slam 3	2024	1	935	187
Slam 4	2024	1	935	187
Made Hoops Tournament 4	2024	2	1,496	597
BlockSports 2	2024	1	1,122	204
Slam 5	2024	1	935	187
Connect Basketball	2024	2	1,496	597
Giveback	2024	2	1,496	707
5k Invitational	2024	3	1,870	1,190
Earned Not Given	2024	3	2,618	1,488
The Finale	2024	3	2,618	2,291
<b>Totals</b>		<b>53</b>	<b>44,880</b>	<b>19,080</b>

7. What specific market will you target with the event/program’s marketing plan? Attach up to 3 examples and evidence of marketing area and readership (Label Exhibit C).

Our sporting tournaments will attract and target basketball and volleyball teams nationwide, encompassing grades 1 through 12 for both boys and girls.

Marketing of our events will be promoted on our website (amerisports.net) through our social media outlets including Facebook, Instagram and TikTok. Also our event sponsors will promote the play and stay during registration.

8. The City of Rockwall must require segregated accounting of its Hotel funds. Organizations must maintain and account for revenue provided from the tax authorized by section 351.101(a) within one of the two options listed below.

- a) Separate checking account without combining with any other revenues or maintained in any other bank account or
- b) Maintain a line-item accounting, whereby the Hotel revenues may not be combined with any other revenues or expenditures. The funds may be maintained in the same bank account, provided they are reported as a separate line item in the organization's budget. Interest earned on the Hotel revenues must be used to support the event/program as well.

Will the organization be able to segregate the accounting process in either a) or b) above?

Yes, AmeriSports will account for Hotel funds by b) maintaining a line-item accounting whereby the Hotel revenues may not be combined with any other revenues or expenditures. The funds may be maintained in the same bank account, provided they are reported as a separate line item in the organization's budget. Interest earned on the Hotel revenues must be used to support the event/program as well.

- 9. Provide all of the following documentation with this application and label each as outlined below.

- Exhibit A Proposed budget for each event/program using attached form
- Exhibit B Letter of determination certifying federal tax exempt 501(c)(3) status
- Exhibit C Examples and evidence of marketing area and readership (limit 3)
- Exhibit D List members of the governing body including name, position, mailing address and phone number
- Exhibit E W-9 Form <https://www.rockwall.com/finance.asp>
- Exhibit F Form 1295 <https://www.rockwall.com/finance.asp>

*We certify, to the best of our ability, that the information in this application, including all exhibits and supporting documentation is true and correct to the best of our knowledge. It is understood and agreed that any funds awarded as a result of this application will be used for the purpose set for herein and the program guidelines.*

Owner /Event Sponsor:

Patrick James

Print Name

Date

08/26/2024

Patrick James  
Signature

Owner /Event Director:

Brad Steveson

Print Name

Date

08/26/2024

Brad Steveson  
Signature

Both signatures are required for the application to be complete.



**EXHIBIT A**

**Hotel Occupancy Tax Funding Request  
Event/Program Budget - Program Year 2025**

Financial information (round to the nearest dollar). Include a completed copy of this budget with funding request application.

Organization Name:	AmeriSports		
Event/Program Name:	Best of the Best Futures	5-Oct	5-Oct
Requested Funding:	\$ 10,000		

Expenses (for this project only)	Total Expenses	HOT Funding \$ Request	Additional Justification for HOT Funding Request
1. Personnel	\$ 2,600		
Administrative	1,800	1,800	Staffing - concession, retail, cust service
Artistic			
Technical			
Other personnel	800	800	Porter and custodial services
2. Fees for outside professional services			
Administrative			
Artistic			
Technical			
3. Space Rental			
4. Equipment Rental			
5. Travel/Transportation			
6. Promotion/Printing	300	300	Event marketing and promotion
7. Costumes/Royalties			
8. Other (supplies, postage etc.)	2,600	2,100	Event food, cleaning and paper supplies + sponsorship funding
9. Sponsorship Partner	0	5,000	City of Rockwall - Sponsorship
10. Total Expenses	5,500	10,000	

Revenues (for this project only)		
1. Total Amount of HOT Fund Request	\$ 10,000	HOT Funding \$ Request
2. Admissions (ticket and concessions)	20,000	Concessions and retail sales
3. Donations		
4. Organizational funds budgeted		
5. Grants (State)		
6. Other (list):	10,000	Rental fees
7. Other (list):		
8. Other (list):		
9. Other (list):		
10. Total income and contributions		
11. Total In-Kind		
12. Total Revenues	40,000	

Financial Information (for this project only)		2022 Actual	2023 Actual	2024 Actual	2025 Proposed
Fiscal Year (Oct. 1st - Sept. 30th)					
Total Revenues(including HOT funds)	\$				40,000
Total Expenses	\$				5,500
Total HOT funds awarded	\$				10,000

**EXHIBIT A**

**Hotel Occupancy Tax Funding Request  
Event/Program Budget - Program Year 2025**

Financial information (round to the nearest dollar). Include a completed copy of this budget with funding request application.

Organization Name:	AmeriSports		
Event/Program Name:	Made Hoops Tournament 1	12-Oct	13-Oct
Requested Funding:	\$ 20,000		

Expenses (for this project only)	Total Expenses	HOT Funding \$ Request	Additional Justification for HOT Funding Request
1. Personnel	\$ 4,400		
Administrative	3,000	3,000	Staffing - concession, retail, cust service
Artistic			
Technical			
Other personnel	1,400	1,400	Porter and custodial services
2. Fees for outside professional services			
Administrative			
Artistic			
Technical			
3. Space Rental			
4. Equipment Rental			
5. Travel/Transportation			
6. Promotion/Printing	600	600	Event marketing and promotion
7. Costumes/Royalties			
8. Other (supplies, postage etc.)	5,200	5,000	Event food, cleaning and paper supplies + sponsorship funding
9. Sponsorship Partner	0	10,000	City of Rockwall - Sponsorship
10. Total Expenses	10,200	20,000	

Revenues (for this project only)		
1. Total Amount of HOT Fund Request	\$ 20,000	HOT Funding \$ Request
2. Admissions (ticket and concessions)	20,000	Concessions and retail sales
3. Donations		
4. Organizational funds budgeted		
5. Grants (State)		
6. Other (list):	10,000	Rental fees
7. Other (list):		
8. Other (list):		
9. Other (list):		
10. Total income and contributions		
11. Total In-Kind		
12. Total Revenues	50,000	

Financial Information (for this project only)		2022 Actual	2023 Actual	2024 Actual	2025 Proposed
Fiscal Year (Oct. 1st - Sept. 30th)					
Total Revenues(including HOT funds)	\$				50,000
Total Expenses	\$				10,200
Total HOT funds awarded	\$				20,000

**EXHIBIT A**

**Hotel Occupancy Tax Funding Request  
Event/Program Budget - Program Year 2025**

Financial information (round to the nearest dollar). Include a completed copy of this budget with funding request application.

Organization Name:	AmeriSports		
Event/Program Name:	Hoops for a Cure	19-Oct	20-Oct
Requested Funding:	\$ 20,000		

Expenses (for this project only)	Total Expenses	HOT Funding \$ Request	Additional Justification for HOT Funding Request
1. Personnel	\$ 4,400		
Administrative	3,000	3,000	Staffing - concession, retail, cust service
Artistic			
Technical			
Other personnel	1,400	1,400	Porter and custodial services
2. Fees for outside professional services			
Administrative			
Artistic			
Technical			
3. Space Rental			
4. Equipment Rental			
5. Travel/Transportation			
6. Promotion/Printing	600	600	Event marketing and promotion
7. Costumes/Royalties			
8. Other (supplies, postage etc.)	5,200	5,000	Event food, cleaning and paper supplies + sponsorship funding
9. Sponsorship Partner	0	10,000	City of Rockwall - Sponsorship
10. Total Expenses	10,200	20,000	

Revenues (for this project only)		
1. Total Amount of HOT Fund Request	\$ 20,000	HOT Funding \$ Request
2. Admissions (ticket and concessions)	20,000	Concessions and retail sales
3. Donations		
4. Organizational funds budgeted		
5. Grants (State)		
6. Other (list):	10,000	Rental fees
7. Other (list):		
8. Other (list):		
9. Other (list):		
10. Total income and contributions		
11. Total In-Kind		
12. Total Revenues	50,000	

Financial Information (for this project only)		2022 Actual	2023 Actual	2024 Actual	2025 Proposed
Fiscal Year (Oct. 1st - Sept. 30th)					
Total Revenues(including HOT funds)	\$				50,000
Total Expenses	\$				10,200
Total HOT funds awarded	\$				20,000

**EXHIBIT A**

**Hotel Occupancy Tax Funding Request  
Event/Program Budget - Program Year 2025**

Financial information (round to the nearest dollar). Include a completed copy of this budget with funding request application.

Organization Name:	AmeriSports		
Event/Program Name:	Basketball Camp	26-Oct	27-Oct
Requested Funding:	\$ 20,000		

Expenses (for this project only)	Total Expenses	HOT Funding \$ Request	Additional Justification for HOT Funding Request
1. Personnel	\$ 4,400		
Administrative	3,000	3,000	Staffing - concession, retail, cust service
Artistic			
Technical			
Other personnel	1,400	1,400	Porter and custodial services
2. Fees for outside professional services			
Administrative			
Artistic			
Technical			
3. Space Rental			
4. Equipment Rental			
5. Travel/Transportation			
6. Promotion/Printing	600	600	Event marketing and promotion
7. Costumes/Royalties			
8. Other (supplies, postage etc.)	5,200	5,000	Event food, cleaning and paper supplies + sponsorship funding
9. Sponsorship Partner	0	10,000	City of Rockwall - Sponsorship
10. Total Expenses	10,200	20,000	

Revenues (for this project only)		
1. Total Amount of HOT Fund Request	\$ 20,000	HOT Funding \$ Request
2. Admissions (ticket and concessions)	20,000	Concessions and retail sales
3. Donations		
4. Organizational funds budgeted		
5. Grants (State)		
6. Other (list):	10,000	Rental fees
7. Other (list):		
8. Other (list):		
9. Other (list):		
10. Total income and contributions		
11. Total In-Kind		
12. Total Revenues	50,000	

Financial Information (for this project only)		2022 Actual	2023 Actual	2024 Actual	2025 Proposed
Fiscal Year (Oct. 1st - Sept. 30th)					
Total Revenues(including HOT funds)	\$				50,000
Total Expenses	\$				10,200
Total HOT funds awarded	\$				20,000

**EXHIBIT A**

**Hotel Occupancy Tax Funding Request  
Event/Program Budget - Program Year 2025**

Financial information (round to the nearest dollar). Include a completed copy of this budget with funding request application.

Organization Name:	AmeriSports		
Event/Program Name:	Hoopfest	7-Dec	8-Dec
Requested Funding:	\$ 20,000		

Expenses (for this project only)	Total Expenses	HOT Funding \$ Request	Additional Justification for HOT Funding Request
1. Personnel	\$ 4,400		
Administrative	3,000	3,000	Staffing - concession, retail, cust service
Artistic			
Technical			
Other personnel	1,400	1,400	Porter and custodial services
2. Fees for outside professional services			
Administrative			
Artistic			
Technical			
3. Space Rental			
4. Equipment Rental			
5. Travel/Transportation			
6. Promotion/Printing	600	600	Event marketing and promotion
7. Costumes/Royalties			
8. Other (supplies, postage etc.)	5,200	5,000	Event food, cleaning and paper supplies + sponsorship funding
9. Sponsorship Partner	0	10,000	City of Rockwall - Sponsorship
10. Total Expenses	10,200	20,000	

Revenues (for this project only)		
1. Total Amount of HOT Fund Request	\$ 20,000	HOT Funding \$ Request
2. Admissions (ticket and concessions)	20,000	Concessions and retail sales
3. Donations		
4. Organizational funds budgeted		
5. Grants (State)		
6. Other (list):	10,000	Rental fees
7. Other (list):		
8. Other (list):		
9. Other (list):		
10. Total income and contributions		
11. Total In-Kind		
12. Total Revenues	50,000	

Financial Information (for this project only)		2022 Actual	2023 Actual	2024 Actual	2025 Proposed
Fiscal Year (Oct. 1st - Sept. 30th)					
Total Revenues(including HOT funds)	\$				50,000
Total Expenses	\$				10,200
Total HOT funds awarded	\$				20,000

**EXHIBIT A**

**Hotel Occupancy Tax Funding Request  
Event/Program Budget - Program Year 2025**

Financial information (round to the nearest dollar). Include a completed copy of this budget with funding request application.

Organization Name:	AmeriSports		
Event/Program Name:	The Season Opener	13-Dec	15-Dec
Requested Funding:	\$ 28,000		

Expenses (for this project only)	Total Expenses	HOT Funding \$ Request	Additional Justification for HOT Funding Request
1. Personnel	\$ 5,560		
Administrative	3,720	3,720	Staffing - concession, retail, cust service
Artistic			
Technical			
Other personnel	1,840	1,840	Porter and custodial services
2. Fees for outside professional services			
Administrative			
Artistic			
Technical			
3. Space Rental			
4. Equipment Rental			
5. Travel/Transportation			
6. Promotion/Printing	900	900	Event marketing and promotion
7. Costumes/Royalties			
8. Other (supplies, postage etc.)	6,540	6,540	Event food, cleaning and paper supplies + sponsorship funding
9. Sponsorship Partner	0	15,000	City of Rockwall - Sponsorship
10. Total Expenses	13,000	28,000	

Revenues (for this project only)		
1. Total Amount of HOT Fund Request	\$ 28,000	HOT Funding \$ Request
2. Admissions (ticket and concessions)	25,000	Concessions and retail sales
3. Donations		
4. Organizational funds budgeted		
5. Grants (State)		
6. Other (list):	13,000	Rental fees
7. Other (list):		
8. Other (list):		
9. Other (list):		
10. Total income and contributions		
11. Total In-Kind		
12. Total Revenues	66,000	

Financial Information (for this project only)		2022 Actual	2023 Actual	2024 Actual	2025 Proposed
Fiscal Year (Oct. 1st - Sept. 30th)					
Total Revenues(including HOT funds)	\$				66,000
Total Expenses	\$				13,000
Total HOT funds awarded	\$				28,000

**EXHIBIT A**

**Hotel Occupancy Tax Funding Request  
Event/Program Budget - Program Year 2025**

Financial information (round to the nearest dollar). Include a completed copy of this budget with funding request application.

Organization Name:	AmeriSports		
Event/Program Name:	BlockSports 1	4-Jan	5-Jan
Requested Funding:	\$ 20,000		

Expenses (for this project only)	Total Expenses	HOT Funding \$ Request	Additional Justification for HOT Funding Request
1. Personnel	\$ 4,400		
Administrative	3,000	3,000	Staffing - concession, retail, cust service
Artistic			
Technical			
Other personnel	1,400	1,400	Porter and custodial services
2. Fees for outside professional services			
Administrative			
Artistic			
Technical			
3. Space Rental			
4. Equipment Rental			
5. Travel/Transportation			
6. Promotion/Printing	600	600	Event marketing and promotion
7. Costumes/Royalties			
8. Other (supplies, postage etc.)	5,200	5,000	Event food, cleaning and paper supplies + sponsorship funding
9. Sponsorship Partner	0	10,000	City of Rockwall - Sponsorship
10. Total Expenses	10,200	20,000	

Revenues (for this project only)		
1. Total Amount of HOT Fund Request	\$ 20,000	HOT Funding \$ Request
2. Admissions (ticket and concessions)	20,000	Concessions and retail sales
3. Donations		
4. Organizational funds budgeted		
5. Grants (State)		
6. Other (list):	10,000	Rental fees
7. Other (list):		
8. Other (list):		
9. Other (list):		
10. Total income and contributions		
11. Total In-Kind		
12. Total Revenues	50,000	

Financial Information (for this project only)		2022 Actual	2023 Actual	2024 Actual	2025 Proposed
Fiscal Year (Oct. 1st - Sept. 30th)					
Total Revenues(Including HOT funds)	\$				50,000
Total Expenses	\$				10,200
Total HOT funds awarded	\$				20,000

**EXHIBIT A**

**Hotel Occupancy Tax Funding Request  
Event/Program Budget - Program Year 2025**

Financial information (round to the nearest dollar). Include a completed copy of this budget with funding request application.

Organization Name:	AmeriSports		
Event/Program Name:	DFW Elite	12-Jan	12-Jan
Requested Funding:	\$ 10,000		

Expenses (for this project only)	Total Expenses	HOT Funding \$ Request	Additional Justification for HOT Funding Request
1. Personnel	\$ 2,600		
Administrative	1,800	1,800	Staffing - concession, retail, cust service
Artistic			
Technical			
Other personnel	800	800	Porter and custodial services
2. Fees for outside professional services			
Administrative			
Artistic			
Technical			
3. Space Rental			
4. Equipment Rental			
5. Travel/Transportation			
6. Promotion/Printing	300	300	Event marketing and promotion
7. Costumes/Royalties			
8. Other (supplies, postage etc.)	2,600	2,100	Event food, cleaning and paper supplies + sponsorship funding
9. Sponsorship Partner	0	5,000	City of Rockwall - Sponsorship
10. Total Expenses	5,500	10,000	

Revenues (for this project only)		
1. Total Amount of HOT Fund Request	\$ 10,000	HOT Funding \$ Request
2. Admissions (ticket and concessions)	20,000	Concessions and retail sales
3. Donations		
4. Organizational funds budgeted		
5. Grants (State)		
6. Other (list):	10,000	Rental fees
7. Other (list):		
8. Other (list):		
9. Other (list):		
10. Total income and contributions		
11. Total In-Kind		
12. Total Revenues	40,000	

Financial Information (for this project only)		2022 Actual	2023 Actual	2024 Actual	2025 Proposed
Fiscal Year (Oct. 1st - Sept. 30th)					
Total Revenues(including HOT funds)	\$				40,000
Total Expenses	\$				5,500
Total HOT funds awarded	\$				10,000



**EXHIBIT A**

**Hotel Occupancy Tax Funding Request  
Event/Program Budget - Program Year 2025**

Financial information (round to the nearest dollar). Include a completed copy of this budget with funding request application.

Organization Name:	AmeriSports		
Event/Program Name:	MLK Super Showcase	18-Jan	19-Jan
Requested Funding:	\$ 20,000		

Expenses (for this project only)	Total Expenses	HOT Funding \$ Request	Additional Justification for HOT Funding Request
1. Personnel	\$ 4,400		
Administrative	3,000	3,000	Staffing - concession, retail, cust service
Artistic			
Technical			
Other personnel	1,400	1,400	Porter and custodial services
2. Fees for outside professional services			
Administrative			
Artistic			
Technical			
3. Space Rental			
4. Equipment Rental			
5. Travel/Transportation			
6. Promotion/Printing	600	600	Event marketing and promotion
7. Costumes/Royalties			
8. Other (supplies, postage etc.)	5,200	5,000	Event food, cleaning and paper supplies + sponsorship funding
9. Sponsorship Partner	0	10,000	City of Rockwall - Sponsorship
10. Total Expenses	10,200	20,000	

Revenues (for this project only)		
1. Total Amount of HOT Fund Request	\$ 20,000	HOT Funding \$ Request
2. Admissions (ticket and concessions)	20,000	Concessions and retail sales
3. Donations		
4. Organizational funds budgeted		
5. Grants (State)		
6. Other (list):	10,000	Rental fees
7. Other (list):		
8. Other (list):		
9. Other (list):		
10. Total income and contributions		
11. Total In-Kind		
12. Total Revenues	50,000	

Financial Information (for this project only)		2022 Actual	2023 Actual	2024 Actual	2025 Proposed
Fiscal Year (Oct. 1st - Sept. 30th)					
Total Revenues(including HOT funds)	\$				50,000
Total Expenses	\$				10,200
Total HOT funds awarded	\$				20,000

**EXHIBIT A**

**Hotel Occupancy Tax Funding Request  
Event/Program Budget - Program Year 2025**

Financial information (round to the nearest dollar). Include a completed copy of this budget with funding request application.

Organization Name:	AmeriSports		
Event/Program Name:	Slam 1	25-Jan	25-Jan
Requested Funding:	\$ 10,000		

Expenses (for this project only)	Total Expenses	HOT Funding \$ Request	Additional Justification for HOT Funding Request
1. Personnel	\$ 2,600		
Administrative	1,800	1,800	Staffing - concession, retail, cust service
Artistic			
Technical			
Other personnel	800	800	Porter and custodial services
2. Fees for outside professional services			
Administrative			
Artistic			
Technical			
3. Space Rental			
4. Equipment Rental			
5. Travel/Transportation			
6. Promotion/Printing	300	300	Event marketing and promotion
7. Costumes/Royalties			
8. Other (supplies, postage etc.)	2,600	2,100	Event food, cleaning and paper supplies + sponsorship funding
9. Sponsorship Partner	0	5,000	City of Rockwall - Sponsorship
10. Total Expenses	5,500	10,000	

Revenues (for this project only)		
1. Total Amount of HOT Fund Request	\$ 10,000	HOT Funding \$ Request
2. Admissions (ticket and concessions)	20,000	Concessions and retail sales
3. Donations		
4. Organizational funds budgeted		
5. Grants (State)		
6. Other (list):	10,000	Rental fees
7. Other (list):		
8. Other (list):		
9. Other (list):		
10. Total income and contributions		
11. Total In-Kind		
12. Total Revenues	40,000	

Financial Information (for this project only)		2022 Actual	2023 Actual	2024 Actual	2025 Proposed
Fiscal Year (Oct. 1st - Sept. 30th)					
Total Revenues(including HOT funds)	\$				40,000
Total Expenses	\$				5,500
Total HOT funds awarded	\$				10,000

**EXHIBIT A**

**Hotel Occupancy Tax Funding Request  
Event/Program Budget - Program Year 2025**

Financial information (round to the nearest dollar). Include a completed copy of this budget with funding request application.

Organization Name:	AmeriSports		
Event/Program Name:	Slam 2	26-Jan	26-Jan
Requested Funding:	\$	10,000	

Expenses (for this project only)	Total Expenses	HOT Funding \$ Request	Additional Justification for HOT Funding Request
1. Personnel	\$ 2,600		
Administrative	1,800	1,800	Staffing - concession, retail, cust service
Artistic			
Technical			
Other personnel	800	800	Porter and custodial services
2. Fees for outside professional services			
Administrative			
Artistic			
Technical			
3. Space Rental			
4. Equipment Rental			
5. Travel/Transportation			
6. Promotion/Printing	300	300	Event marketing and promotion
7. Costumes/Royalties			
8. Other (supplies, postage etc.)	2,600	2,100	Event food, cleaning and paper supplies + sponsorship funding
9. Sponsorship Partner	0	5,000	City of Rockwall - Sponsorship
10. Total Expenses	5,500	10,000	

Revenues (for this project only)		
1. Total Amount of HOT Fund Request	\$ 10,000	HOT Funding \$ Request
2. Admissions (ticket and concessions)	20,000	Concessions and retail sales
3. Donations		
4. Organizational funds budgeted		
5. Grants (State)		
6. Other (list):	10,000	Rental fees
7. Other (list):		
8. Other (list):		
9. Other (list):		
10. Total income and contributions		
11. Total In-Kind		
12. Total Revenues	40,000	

Financial Information (for this project only)		2022 Actual	2023 Actual	2024 Actual	2025 Proposed
Fiscal Year (Oct. 1st - Sept. 30th)					
Total Revenues(including HOT funds)	\$				40,000
Total Expenses	\$				5,500
Total HOT funds awarded	\$				10,000

**EXHIBIT A**

**Hotel Occupancy Tax Funding Request  
Event/Program Budget - Program Year 2025**

Financial information (round to the nearest dollar). Include a completed copy of this budget with funding request application.

Organization Name:	AmeriSports		
Event/Program Name:	Love & Basketball	1-Feb	2-Feb
Requested Funding:	\$ 20,000		

Expenses (for this project only)	Total Expenses	HOT Funding \$ Request	Additional Justification for HOT Funding Request
1. Personnel	\$ 4,400		
Administrative	3,000	3,000	Staffing - concession, retail, cust service
Artistic			
Technical			
Other personnel	1,400	1,400	Porter and custodial services
2. Fees for outside professional services			
Administrative			
Artistic			
Technical			
3. Space Rental			
4. Equipment Rental			
5. Travel/Transportation			
6. Promotion/Printing	600	600	Event marketing and promotion
7. Costumes/Royalties			
8. Other (supplies, postage etc.)	5,200	5,000	Event food, cleaning and paper supplies + sponsorship funding
9. Sponsorship Partner	0	10,000	City of Rockwall - Sponsorship
10. Total Expenses	10,200	20,000	

Revenues (for this project only)		
1. Total Amount of HOT Fund Request	\$ 20,000	HOT Funding \$ Request
2. Admissions (ticket and concessions)	20,000	Concessions and retail sales
3. Donations		
4. Organizational funds budgeted		
5. Grants (State)		
6. Other (list):	10,000	Rental fees
7. Other (list):		
8. Other (list):		
9. Other (list):		
10. Total income and contributions		
11. Total In-Kind		
12. Total Revenues	50,000	

Financial Information (for this project only)		2022 Actual	2023 Actual	2024 Actual	2025 Proposed
Fiscal Year (Oct. 1st - Sept. 30th)					
Total Revenues(including HOT funds)	\$				50,000
Total Expenses	\$				10,200
Total HOT funds awarded	\$				20,000

**EXHIBIT A**

**Hotel Occupancy Tax Funding Request  
Event/Program Budget - Program Year 2025**

Financial information (round to the nearest dollar). Include a completed copy of this budget with funding request application.

Organization Name:	AmeriSports		
Event/Program Name:	Heart of City	8-Feb	9-Feb
Requested Funding:	\$ 20,000		

Expenses (for this project only)	Total Expenses	HOT Funding \$ Request	Additional Justification for HOT Funding Request
1. Personnel	\$ 4,400		
Administrative	3,000	3,000	Staffing - concession, retail, cust service
Artistic			
Technical			
Other personnel	1,400	1,400	Porter and custodial services
2. Fees for outside professional services			
Administrative			
Artistic			
Technical			
3. Space Rental			
4. Equipment Rental			
5. Travel/Transportation			
6. Promotion/Printing	600	600	Event marketing and promotion
7. Costumes/Royalties			
8. Other (supplies, postage etc.)	5,200	5,000	Event food, cleaning and paper supplies + sponsorship funding
9. Sponsorship Partner	0	10,000	City of Rockwall - Sponsorship
10. Total Expenses	10,200	20,000	

Revenues (for this project only)		
1. Total Amount of HOT Fund Request	\$ 20,000	HOT Funding \$ Request
2. Admissions (ticket and concessions)	20,000	Concessions and retail sales
3. Donations		
4. Organizational funds budgeted		
5. Grants (State)		
6. Other (list):	10,000	Rental fees
7. Other (list):		
8. Other (list):		
9. Other (list):		
10. Total income and contributions		
11. Total In-Kind		
12. Total Revenues	50,000	

Financial Information (for this project only)		2022 Actual	2023 Actual	2024 Actual	2025 Proposed
Fiscal Year (Oct. 1st - Sept. 30th)					
Total Revenues(including HOT funds)	\$				50,000
Total Expenses	\$				10,200
Total HOT funds awarded	\$				20,000

**EXHIBIT A**

**Hotel Occupancy Tax Funding Request  
Event/Program Budget - Program Year 2025**

Financial information (round to the nearest dollar). Include a completed copy of this budget with funding request application.

Organization Name:	AmeriSports		
Event/Program Name:	Rockwall Rumble	15-Feb	16-Feb
Requested Funding:	\$ 20,000		

Expenses (for this project only)	Total Expenses	HOT Funding \$ Request	Additional Justification for HOT Funding Request
1. Personnel	\$ 4,400		
Administrative	3,000	3,000	Staffing - concession, retail, cust service
Artistic			
Technical			
Other personnel	1,400	1,400	Porter and custodial services
2. Fees for outside professional services			
Administrative			
Artistic			
Technical			
3. Space Rental			
4. Equipment Rental			
5. Travel/Transportation			
6. Promotion/Printing	600	600	Event marketing and promotion
7. Costumes/Royalties			
8. Other (supplies, postage etc.)	5,200	5,000	Event food, cleaning and paper supplies + sponsorship funding
9. Sponsorship Partner	0	10,000	City of Rockwall - Sponsorship
10. Total Expenses	10,200	20,000	

Revenues (for this project only)		
1. Total Amount of HOT Fund Request	\$ 20,000	HOT Funding \$ Request
2. Admissions (ticket and concessions)	20,000	Concessions and retail sales
3. Donations		
4. Organizational funds budgeted		
5. Grants (State)		
6. Other (list):	10,000	Rental fees
7. Other (list):		
8. Other (list):		
9. Other (list):		
10. Total income and contributions		
11. Total In-Kind		
12. Total Revenues	50,000	

Financial Information (for this project only)		2022 Actual	2023 Actual	2024 Actual	2025 Proposed
Fiscal Year (Oct. 1st - Sept. 30th)					
Total Revenues(including HOT funds)	\$				50,000
Total Expenses	\$				10,200
Total HOT funds awarded	\$				20,000

**EXHIBIT A**

**Hotel Occupancy Tax Funding Request  
Event/Program Budget - Program Year 2025**

Financial information (round to the nearest dollar). Include a completed copy of this budget with funding request application.

Organization Name:	AmeriSports		
Event/Program Name:	Made Hoops Tournament 2	22-Feb	23-Feb
Requested Funding:	\$ 20,000		

Expenses (for this project only)	Total Expenses	HOT Funding \$ Request	Additional Justification for HOT Funding Request
1. Personnel	\$ 4,400		
Administrative	3,000	3,000	Staffing - concession, retail, cust service
Artistic			
Technical			
Other personnel	1,400	1,400	Porter and custodial services
2. Fees for outside professional services			
Administrative			
Artistic			
Technical			
3. Space Rental			
4. Equipment Rental			
5. Travel/Transportation			
6. Promotion/Printing	600	600	Event marketing and promotion
7. Costumes/Royalties			
8. Other (supplies, postage etc.)	5,200	5,000	Event food, cleaning and paper supplies + sponsorship funding
9. Sponsorship Partner	0	10,000	City of Rockwall - Sponsorship
10. Total Expenses	10,200	20,000	

Revenues (for this project only)		
1. Total Amount of HOT Fund Request	\$ 20,000	HOT Funding \$ Request
2. Admissions (ticket and concessions)	20,000	Concessions and retail sales
3. Donations		
4. Organizational funds budgeted		
5. Grants (State)		
6. Other (list):	10,000	Rental fees
7. Other (list):		
8. Other (list):		
9. Other (list):		
10. Total income and contributions		
11. Total In-Kind		
12. Total Revenues	50,000	

Financial Information (for this project only)		2022 Actual	2023 Actual	2024 Actual	2025 Proposed
Fiscal Year (Oct. 1st - Sept. 30th)					
Total Revenues(including HOT funds)	\$				50,000
Total Expenses	\$				10,200
Total HOT funds awarded	\$				20,000

**EXHIBIT A**

**Hotel Occupancy Tax Funding Request  
Event/Program Budget - Program Year 2025**

Financial information (round to the nearest dollar). Include a completed copy of this budget with funding request application.

Organization Name:	AmeriSports		
Event/Program Name:	Made Hoops Tournament 3	1-Mar	2-Mar
Requested Funding:	\$ 20,000		

Expenses (for this project only)	Total Expenses	HOT Funding \$ Request	Additional Justification for HOT Funding Request
1. Personnel	\$ 4,400		
Administrative	3,000	3,000	Staffing - concession, retail, cust service
Artistic			
Technical			
Other personnel	1,400	1,400	Porter and custodial services
2. Fees for outside professional services			
Administrative			
Artistic			
Technical			
3. Space Rental			
4. Equipment Rental			
5. Travel/Transportation			
6. Promotion/Printing	600	600	Event marketing and promotion
7. Costumes/Royalties			
8. Other (supplies, postage etc.)	5,200	5,000	Event food, cleaning and paper supplies + sponsorship funding
9. Sponsorship Partner	0	10,000	City of Rockwall - Sponsorship
10. Total Expenses	10,200	20,000	

Revenues (for this project only)		
1. Total Amount of HOT Fund Request	\$ 20,000	HOT Funding \$ Request
2. Admissions (ticket and concessions)	20,000	Concessions and retail sales
3. Donations		
4. Organizational funds budgeted		
5. Grants (State)		
6. Other (list):	10,000	Rental fees
7. Other (list):		
8. Other (list):		
9. Other (list):		
10. Total income and contributions		
11. Total In-Kind		
12. Total Revenues	50,000	

Financial Information (for this project only)		2022 Actual	2023 Actual	2024 Actual	2025 Proposed
Fiscal Year (Oct. 1st - Sept. 30th)					
Total Revenues(including HOT funds)	\$				50,000
Total Expenses	\$				10,200
Total HOT funds awarded	\$				20,000



**EXHIBIT A**

**Hotel Occupancy Tax Funding Request  
Event/Program Budget - Program Year 2025**

Financial information (round to the nearest dollar). Include a completed copy of this budget with funding request application.

Organization Name:	AmeriSports		
Event/Program Name:	BlockSports	8-Mar	9-Mar
Requested Funding:	\$ 20,000		

Expenses (for this project only)	Total Expenses	HOT Funding \$ Request	Additional Justification for HOT Funding Request
1. Personnel	\$ 4,400		
Administrative	3,000	3,000	Staffing - concession, retail, cust service
Artistic			
Technical			
Other personnel	1,400	1,400	Porter and custodial services
2. Fees for outside professional services			
Administrative			
Artistic			
Technical			
3. Space Rental			
4. Equipment Rental			
5. Travel/Transportation			
6. Promotion/Printing	600	600	Event marketing and promotion
7. Costumes/Royalties			
8. Other (supplies, postage etc.)	5,200	5,000	Event food, cleaning and paper supplies + sponsorship funding
9. Sponsorship Partner	0	10,000	City of Rockwall - Sponsorship
10. Total Expenses	10,200	20,000	

Revenues (for this project only)		
1. Total Amount of HOT Fund Request	\$ 20,000	HOT Funding \$ Request
2. Admissions (ticket and concessions)	20,000	Concessions and retail sales
3. Donations		
4. Organizational funds budgeted		
5. Grants (State)		
6. Other (list):	10,000	Rental fees
7. Other (list):		
8. Other (list):		
9. Other (list):		
10. Total income and contributions		
11. Total In-Kind		
12. Total Revenues	50,000	

Financial Information (for this project only)		2022 Actual	2023 Actual	2024 Actual	2025 Proposed
Fiscal Year (Oct. 1st - Sept. 30th)					
Total Revenues(Including HOT funds)	\$				50,000
Total Expenses	\$				10,200
Total HOT funds awarded	\$				20,000

**EXHIBIT A**

**Hotel Occupancy Tax Funding Request  
Event/Program Budget - Program Year 2025**

Financial information (round to the nearest dollar). Include a completed copy of this budget with funding request application.

Organization Name:	AmeriSports		
Event/Program Name:	10K Invitational	14-Mar	16-Mar
Requested Funding:	\$ 28,000		

Expenses (for this project only)	Total Expenses	HOT Funding \$ Request	Additional Justification for HOT Funding Request
1. Personnel	\$ 5,560		
Administrative	3,720	3,720	Staffing - concession, retail, cust service
Artistic			
Technical			
Other personnel	1,840	1,840	Porter and custodial services
2. Fees for outside professional services			
Administrative			
Artistic			
Technical			
3. Space Rental			
4. Equipment Rental			
5. Travel/Transportation			
6. Promotion/Printing	900	900	Event marketing and promotion
7. Costumes/Royalties			
8. Other (supplies, postage etc.)	6,540	6,540	Event food, cleaning and paper supplies + sponsorship funding
9. Sponsorship Partner	0	15,000	City of Rockwall - Sponsorship
10. Total Expenses	13,000	28,000	

Revenues (for this project only)		
1. Total Amount of HOT Fund Request	\$ 28,000	HOT Funding \$ Request
2. Admissions (ticket and concessions)	25,000	Concessions and retail sales
3. Donations		
4. Organizational funds budgeted		
5. Grants (State)		
6. Other (list):	13,000	Rental fees
7. Other (list):		
8. Other (list):		
9. Other (list):		
10. Total income and contributions		
11. Total In-Kind		
12. Total Revenues	66,000	

Financial Information (for this project only)		2022 Actual	2023 Actual	2024 Actual	2025 Proposed
Fiscal Year (Oct. 1st - Sept. 30th)					
Total Revenues(including HOT funds)	\$				66,000
Total Expenses	\$				13,000
Total HOT funds awarded	\$				28,000

**EXHIBIT A**

**Hotel Occupancy Tax Funding Request  
Event/Program Budget - Program Year 2025**

Financial information (round to the nearest dollar). Include a completed copy of this budget with funding request application.

Organization Name:	AmeriSports		
Event/Program Name:	Slam 3	22-Mar	22-Mar
Requested Funding:	\$ 10,000		

Expenses (for this project only)	Total Expenses	HOT Funding \$ Request	Additional Justification for HOT Funding Request
1. Personnel	\$ 2,600		
Administrative	1,800	1,800	Staffing - concession, retail, cust service
Artistic			
Technical			
Other personnel	800	800	Porter and custodial services
2. Fees for outside professional services			
Administrative			
Artistic			
Technical			
3. Space Rental			
4. Equipment Rental			
5. Travel/Transportation			
6. Promotion/Printing	300	300	Event marketing and promotion
7. Costumes/Royalties			
8. Other (supplies, postage etc.)	2,600	2,100	Event food, cleaning and paper supplies + sponsorship funding
9. Sponsorship Partner	0	5,000	City of Rockwall - Sponsorship
10. Total Expenses	5,500	10,000	

Revenues (for this project only)		
1. Total Amount of HOT Fund Request	\$ 10,000	HOT Funding \$ Request
2. Admissions (ticket and concessions)	20,000	Concessions and retail sales
3. Donations		
4. Organizational funds budgeted		
5. Grants (State)		
6. Other (list):	10,000	Rental fees
7. Other (list):		
8. Other (list):		
9. Other (list):		
10. Total income and contributions		
11. Total In-Kind		
12. Total Revenues	40,000	

Financial Information (for this project only)		2022 Actual	2023 Actual	2024 Actual	2025 Proposed
Fiscal Year (Oct. 1st - Sept. 30th)					
Total Revenues(including HOT funds)	\$				40,000
Total Expenses	\$				5,500
Total HOT funds awarded	\$				10,000

**EXHIBIT A**

**Hotel Occupancy Tax Funding Request  
Event/Program Budget - Program Year 2025**

Financial information (round to the nearest dollar). Include a completed copy of this budget with funding request application.

Organization Name:	AmeriSports		
Event/Program Name:	Slam 4	29-Mar	29-Mar
Requested Funding:	\$ 10,000		

Expenses (for this project only)	Total Expenses	HOT Funding \$ Request	Additional Justification for HOT Funding Request
1. Personnel	\$ 2,600		
Administrative	1,800	1,800	Staffing - concession, retail, cust service
Artistic			
Technical			
Other personnel	800	800	Porter and custodial services
2. Fees for outside professional services			
Administrative			
Artistic			
Technical			
3. Space Rental			
4. Equipment Rental			
5. Travel/Transportation			
6. Promotion/Printing	300	300	Event marketing and promotion
7. Costumes/Royalties			
8. Other (supplies, postage etc.)	2,600	2,100	Event food, cleaning and paper supplies + sponsorship funding
9. Sponsorship Partner	0	5,000	City of Rockwall - Sponsorship
10. Total Expenses	5,500	10,000	

Revenues (for this project only)		
1. Total Amount of HOT Fund Request	\$ 10,000	HOT Funding \$ Request
2. Admissions (ticket and concessions)	20,000	Concessions and retail sales
3. Donations		
4. Organizational funds budgeted		
5. Grants (State)		
6. Other (list):	10,000	Rental fees
7. Other (list):		
8. Other (list):		
9. Other (list):		
10. Total income and contributions		
11. Total In-Kind		
12. Total Revenues	40,000	

Financial Information (for this project only)		2022 Actual	2023 Actual	2024 Actual	2025 Proposed
Fiscal Year (Oct. 1st - Sept. 30th)					
Total Revenues(including HOT funds)	\$				40,000
Total Expenses	\$				5,500
Total HOT funds awarded	\$				10,000

**EXHIBIT A**

**Hotel Occupancy Tax Funding Request  
Event/Program Budget - Program Year 2025**

Financial information (round to the nearest dollar). Include a completed copy of this budget with funding request application.

Organization Name:	AmeriSports		
Event/Program Name:	Made Hoops Tournament 4	5-Apr	6-Apr
Requested Funding:	\$ 20,000		

Expenses (for this project only)	Total Expenses	HOT Funding \$ Request	Additional Justification for HOT Funding Request
1. Personnel	\$ 4,400		
Administrative	3,000	3,000	Staffing - concession, retail, cust service
Artistic			
Technical			
Other personnel	1,400	1,400	Porter and custodial services
2. Fees for outside professional services			
Administrative			
Artistic			
Technical			
3. Space Rental			
4. Equipment Rental			
5. Travel/Transportation			
6. Promotion/Printing	600	600	Event marketing and promotion
7. Costumes/Royalties			
8. Other (supplies, postage etc.)	5,200	5,000	Event food, cleaning and paper supplies + sponsorship funding
9. Sponsorship Partner	0	10,000	City of Rockwall - Sponsorship
10. Total Expenses	10,200	20,000	

Revenues (for this project only)		
1. Total Amount of HOT Fund Request	\$ 20,000	HOT Funding \$ Request
2. Admissions (ticket and concessions)	20,000	Concessions and retail sales
3. Donations		
4. Organizational funds budgeted		
5. Grants (State)		
6. Other (list):	10,000	Rental fees
7. Other (list):		
8. Other (list):		
9. Other (list):		
10. Total income and contributions		
11. Total In-Kind		
12. Total Revenues	50,000	

Financial Information (for this project only)		2022 Actual	2023 Actual	2024 Actual	2025 Proposed
Fiscal Year (Oct. 1st - Sept. 30th)					
Total Revenues(including HOT funds)	\$				50,000
Total Expenses	\$				10,200
Total HOT funds awarded	\$				20,000

**EXHIBIT A**

**Hotel Occupancy Tax Funding Request  
Event/Program Budget - Program Year 2025**

Financial information (round to the nearest dollar). Include a completed copy of this budget with funding request application.

Organization Name:	AmeriSports		
Event/Program Name:	BlockSports 2	13-Apr	13-Apr
Requested Funding:	\$ 10,000		

Expenses (for this project only)	Total Expenses	HOT Funding \$ Request	Additional Justification for HOT Funding Request
1. Personnel	\$ 2,600		
Administrative	1,800	1,800	Staffing - concession, retail, cust service
Artistic			
Technical			
Other personnel	800	800	Porter and custodial services
2. Fees for outside professional services			
Administrative			
Artistic			
Technical			
3. Space Rental			
4. Equipment Rental			
5. Travel/Transportation			
6. Promotion/Printing	300	300	Event marketing and promotion
7. Costumes/Royalties			
8. Other (supplies, postage etc.)	2,600	2,100	Event food, cleaning and paper supplies + sponsorship funding
9. Sponsorship Partner	0	5,000	City of Rockwall - Sponsorship
10. Total Expenses	5,500	10,000	

Revenues (for this project only)		
1. Total Amount of HOT Fund Request	\$ 10,000	HOT Funding \$ Request
2. Admissions (ticket and concessions)	20,000	Concessions and retail sales
3. Donations		
4. Organizational funds budgeted		
5. Grants (State)		
6. Other (list):	10,000	Rental fees
7. Other (list):		
8. Other (list):		
9. Other (list):		
10. Total income and contributions		
11. Total In-Kind		
12. Total Revenues	40,000	

Financial Information (for this project only)		2022 Actual	2023 Actual	2024 Actual	2025 Proposed
Fiscal Year (Oct. 1st - Sept. 30th)					
Total Revenues(including HOT funds)	\$				40,000
Total Expenses	\$				5,500
Total HOT funds awarded	\$				10,000

**EXHIBIT A**

**Hotel Occupancy Tax Funding Request  
Event/Program Budget - Program Year 2025**

Financial information (round to the nearest dollar). Include a completed copy of this budget with funding request application.

Organization Name:	AmeriSports		
Event/Program Name:	Slam 5	26-Apr	26-Apr
Requested Funding:	\$ 10,000		

Expenses (for this project only)	Total Expenses	HOT Funding \$ Request	Additional Justification for HOT Funding Request
1. Personnel	\$ 2,600		
Administrative	1,800	1,800	Staffing - concession, retail, cust service
Artistic			
Technical			
Other personnel	800	800	Porter and custodial services
2. Fees for outside professional services			
Administrative			
Artistic			
Technical			
3. Space Rental			
4. Equipment Rental			
5. Travel/Transportation			
6. Promotion/Printing	300	300	Event marketing and promotion
7. Costumes/Royalties			
8. Other (supplies, postage etc.)	2,600	2,100	Event food, cleaning and paper supplies + sponsorship funding
9. Sponsorship Partner	0	5,000	City of Rockwall - Sponsorship
10. Total Expenses	5,500	10,000	

Revenues (for this project only)		
1. Total Amount of HOT Fund Request	\$ 10,000	HOT Funding \$ Request
2. Admissions (ticket and concessions)	20,000	Concessions and retail sales
3. Donations		
4. Organizational funds budgeted		
5. Grants (State)		
6. Other (list):	10,000	Rental fees
7. Other (list):		
8. Other (list):		
9. Other (list):		
10. Total income and contributions		
11. Total In-Kind		
12. Total Revenues	40,000	

Financial Information (for this project only)		2022 Actual	2023 Actual	2024 Actual	2025 Proposed
Fiscal Year (Oct. 1st - Sept. 30th)					
Total Revenues(including HOT funds)	\$				40,000
Total Expenses	\$				5,500
Total HOT funds awarded	\$				10,000

**EXHIBIT A**

**Hotel Occupancy Tax Funding Request  
Event/Program Budget - Program Year 2025**

Financial information (round to the nearest dollar). Include a completed copy of this budget with funding request application.

Organization Name:	AmeriSports		
Event/Program Name:	Connect Basketball	17-May	18-May
Requested Funding:	\$ 20,000		

Expenses (for this project only)	Total Expenses	HOT Funding \$ Request	Additional Justification for HOT Funding Request
1. Personnel	\$ 4,400		
Administrative	3,000	3,000	Staffing - concession, retail, cust service
Artistic			
Technical			
Other personnel	1,400	1,400	Porter and custodial services
2. Fees for outside professional services			
Administrative			
Artistic			
Technical			
3. Space Rental			
4. Equipment Rental			
5. Travel/Transportation			
6. Promotion/Printing	600	600	Event marketing and promotion
7. Costumes/Royalties			
8. Other (supplies, postage etc.)	5,200	5,000	Event food, cleaning and paper supplies + sponsorship funding
9. Sponsorship Partner	0	10,000	City of Rockwall - Sponsorship
10. Total Expenses	10,200	20,000	

Revenues (for this project only)		
1. Total Amount of HOT Fund Request	\$ 20,000	HOT Funding \$ Request
2. Admissions (ticket and concessions)	20,000	Concessions and retail sales
3. Donations		
4. Organizational funds budgeted		
5. Grants (State)		
6. Other (list):	10,000	Rental fees
7. Other (list):		
8. Other (list):		
9. Other (list):		
10. Total income and contributions		
11. Total In-Kind		
12. Total Revenues	50,000	

Financial Information (for this project only)		2022 Actual	2023 Actual	2024 Actual	2025 Proposed
Fiscal Year (Oct. 1st - Sept. 30th)					
Total Revenues(including HOT funds)	\$				50,000
Total Expenses	\$				10,200
Total HOT funds awarded	\$				20,000



**EXHIBIT A**

**Hotel Occupancy Tax Funding Request  
Event/Program Budget - Program Year 2025**

Financial information (round to the nearest dollar). Include a completed copy of this budget with funding request application.

Organization Name:	AmeriSports		
Event/Program Name:	Giveback	24-May	25-May
Requested Funding:	\$ 20,000		

Expenses (for this project only)	Total Expenses	HOT Funding \$ Request	Additional Justification for HOT Funding Request
1. Personnel	\$ 4,400		
Administrative	3,000	3,000	Staffing - concession, retail, cust service
Artistic			
Technical			
Other personnel	1,400	1,400	Porter and custodial services
2. Fees for outside professional services			
Administrative			
Artistic			
Technical			
3. Space Rental			
4. Equipment Rental			
5. Travel/Transportation			
6. Promotion/Printing	600	600	Event marketing and promotion
7. Costumes/Royalties			
8. Other (supplies, postage etc.)	5,200	5,000	Event food, cleaning and paper supplies + sponsorship funding
9. Sponsorship Partner	0	10,000	City of Rockwall - Sponsorship
10. Total Expenses	10,200	20,000	

Revenues (for this project only)		
1. Total Amount of HOT Fund Request	\$ 20,000	HOT Funding \$ Request
2. Admissions (ticket and concessions)	20,000	Concessions and retail sales
3. Donations		
4. Organizational funds budgeted		
5. Grants (State)		
6. Other (list):	10,000	Rental fees
7. Other (list):		
8. Other (list):		
9. Other (list):		
10. Total income and contributions		
11. Total In-Kind		
12. Total Revenues	50,000	

Financial Information (for this project only)		2022 Actual	2023 Actual	2024 Actual	2025 Proposed
Fiscal Year (Oct. 1st - Sept. 30th)					
Total Revenues(including HOT funds)	\$				50,000
Total Expenses	\$				10,200
Total HOT funds awarded	\$				20,000

**EXHIBIT A**

**Hotel Occupancy Tax Funding Request  
Event/Program Budget - Program Year 2025**

Financial information (round to the nearest dollar). Include a completed copy of this budget with funding request application.

Organization Name:	AmeriSports		
Event/Program Name:	5k Invitational	6-Jun	8-Jun
Requested Funding:	\$ 28,000		

Expenses (for this project only)	Total Expenses	HOT Funding \$ Request	Additional Justification for HOT Funding Request
1. Personnel	\$ 5,560		
Administrative	3,720	3,720	Staffing - concession, retail, cust service
Artistic			
Technical			
Other personnel	1,840	1,840	Porter and custodial services
2. Fees for outside professional services			
Administrative			
Artistic			
Technical			
3. Space Rental			
4. Equipment Rental			
5. Travel/Transportation			
6. Promotion/Printing	900	900	Event marketing and promotion
7. Costumes/Royalties			
8. Other (supplies, postage etc.)	6,540	6,540	Event food, cleaning and paper supplies + sponsorship funding
9. Sponsorship Partner	0	15,000	City of Rockwall - Sponsorship
10. Total Expenses	13,000	28,000	

Revenues (for this project only)		
1. Total Amount of HOT Fund Request	\$ 28,000	HOT Funding \$ Request
2. Admissions (ticket and concessions)	25,000	Concessions and retail sales
3. Donations		
4. Organizational funds budgeted		
5. Grants (State)		
6. Other (list):	13,000	Rental fees
7. Other (list):		
8. Other (list):		
9. Other (list):		
10. Total income and contributions		
11. Total In-Kind		
12. Total Revenues	66,000	

Financial Information (for this project only)		2022 Actual	2023 Actual	2024 Actual	2025 Proposed
Fiscal Year (Oct. 1st - Sept. 30th)					
Total Revenues(including HOT funds)	\$				66,000
Total Expenses	\$				13,000
Total HOT funds awarded	\$				28,000

**EXHIBIT A**

**Hotel Occupancy Tax Funding Request  
Event/Program Budget - Program Year 2025**

Financial information (round to the nearest dollar). Include a completed copy of this budget with funding request application.

Organization Name:	AmeriSports		
Event/Program Name:	Earned Not Given	27-Jun	29-Jun
Requested Funding:	\$ 28,000		

Expenses (for this project only)	Total Expenses	HOT Funding \$ Request	Additional Justification for HOT Funding Request
1. Personnel	\$ 5,560		
Administrative	3,720	3,720	Staffing - concession, retail, cust service
Artistic			
Technical			
Other personnel	1,840	1,840	Porter and custodial services
2. Fees for outside professional services			
Administrative			
Artistic			
Technical			
3. Space Rental			
4. Equipment Rental			
5. Travel/Transportation			
6. Promotion/Printing	900	900	Event marketing and promotion
7. Costumes/Royalties			
8. Other (supplies, postage etc.)	6,540	6,540	Event food, cleaning and paper supplies + sponsorship funding
9. Sponsorship Partner	0	15,000	City of Rockwall - Sponsorship
10. Total Expenses	13,000	28,000	

Revenues (for this project only)		
1. Total Amount of HOT Fund Request	\$ 28,000	HOT Funding \$ Request
2. Admissions (ticket and concessions)	25,000	Concessions and retail sales
3. Donations		
4. Organizational funds budgeted		
5. Grants (State)		
6. Other (list):	13,000	Rental fees
7. Other (list):		
8. Other (list):		
9. Other (list):		
10. Total income and contributions		
11. Total In-Kind		
12. Total Revenues	66,000	

Financial Information (for this project only)		2022 Actual	2023 Actual	2024 Actual	2025 Proposed
Fiscal Year (Oct. 1st - Sept. 30th)					
Total Revenues(including HOT funds)	\$				66,000
Total Expenses	\$				13,000
Total HOT funds awarded	\$				28,000

**EXHIBIT A**

**Hotel Occupancy Tax Funding Request  
Event/Program Budget - Program Year 2025**

Financial information (round to the nearest dollar). Include a completed copy of this budget with funding request application.

Organization Name:	AmeriSports		
Event/Program Name:	The Finale	1-Aug	3-Aug
Requested Funding:	\$ 28,000		

Expenses (for this project only)	Total Expenses	HOT Funding \$ Request	Additional Justification for HOT Funding Request
1. Personnel	\$ 5,560		
Administrative	3,720	3,720	Staffing - concession, retail, cust service
Artistic			
Technical			
Other personnel	1,840	1,840	Porter and custodial services
2. Fees for outside professional services			
Administrative			
Artistic			
Technical			
3. Space Rental			
4. Equipment Rental			
5. Travel/Transportation			
6. Promotion/Printing	900	900	Event marketing and promotion
7. Costumes/Royalties			
8. Other (supplies, postage etc.)	6,540	6,540	Event food, cleaning and paper supplies + sponsorship funding
9. Sponsorship Partner	0	15,000	City of Rockwall - Sponsorship
10. Total Expenses	13,000	28,000	

Revenues (for this project only)		
1. Total Amount of HOT Fund Request	\$ 28,000	HOT Funding \$ Request
2. Admissions (ticket and concessions)	25,000	Concessions and retail sales
3. Donations		
4. Organizational funds budgeted		
5. Grants (State)		
6. Other (list):	13,000	Rental fees
7. Other (list):		
8. Other (list):		
9. Other (list):		
10. Total income and contributions		
11. Total In-Kind		
12. Total Revenues	66,000	

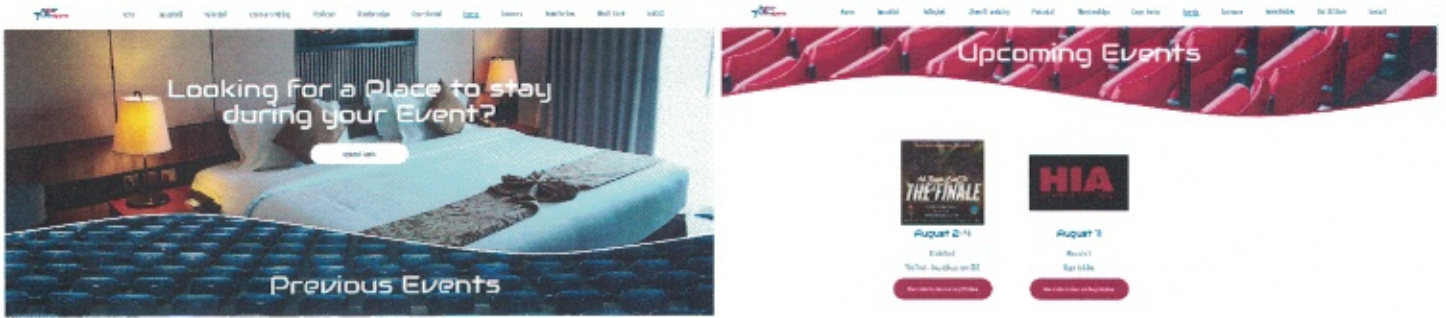
Financial Information (for this project only)		2022 Actual	2023 Actual	2024 Actual	2025 Proposed
Fiscal Year (Oct. 1st - Sept. 30th)					
Total Revenues(including HOT funds)	\$				66,000
Total Expenses	\$				13,000
Total HOT funds awarded	\$				28,000

**Exhibit B**  
**Letter of determination certifying federal tax exempt 501(c)(3) status**

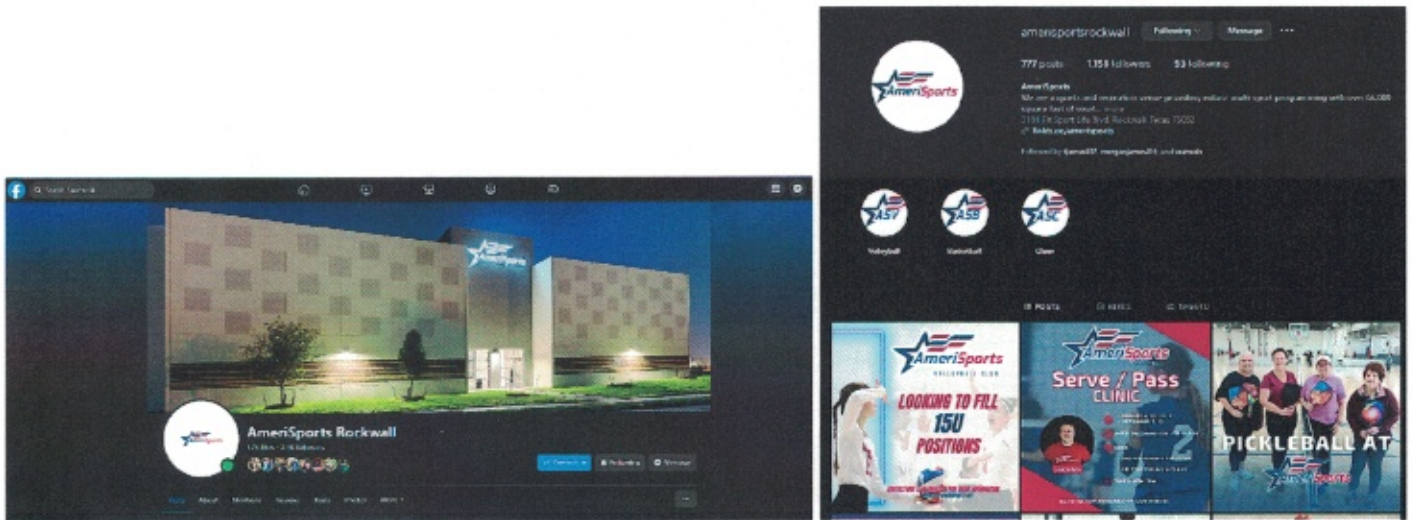
AmeriSports is NOT tax exempt

**Exhibit C**  
**Examples and evidence of marketing and readership (limit 3)**

**Website - AmeriSports.net**



**Social Media – Facebook / Instagram**



**Exhibit D**

**List members of the governing body including name, position, mailing address  
and phone number**

Patrick James

- Owner
- 2829 Lago Vista Ln / Rockwall TX 75032
- 469-261-5803

Brad Steveson

- Owner
- 2215 Kings Pass / Heath TX 75032
- 615-509-0101

Exhibit E  
W-9 Form

Docusign Envelope ID: EC734C4D-E1AB-40BF-B5FA-D6A020A0996F

**W-9**  
Form  
(Rev. March 2024)  
Department of the Treasury  
Internal Revenue Service

**Request for Taxpayer  
Identification Number and Certification**

Go to [www.irs.gov/FormW9](http://www.irs.gov/FormW9) for instructions and the latest information.

Give form to the  
requester. Do not  
send to the IRS.

**Before you begin.** For guidance related to the purpose of Form W-9, see *Purpose of Form*, below.

**1** Name of entity/individual. An entry is required. (For a sole proprietor or disregarded entity, enter the owner's name on line 1, and enter the business/disregarded entity's name on line 2.)  
**AmeriSports, LLC**

**2** Business name/disregarded entity name, if different from above.

**3a** Check the appropriate box for federal tax classification of the entity/individual whose name is entered on line 1. Check only **one** of the following seven boxes.  
 Individual/sole proprietor     C corporation     S corporation     Partnership     Trust/estate  
 LLC. Enter the tax classification (C = C corporation, S = S corporation, P = Partnership) **P**  
**Note:** Check the "LLC" box above and, in the entry space, enter the appropriate code (C, S, or P) for the tax classification of the LLC, unless it is a disregarded entity. A disregarded entity should instead check the appropriate box for the tax classification of its owner.  
 Other (see instructions)

**4** Exemptions (codes apply only to certain entities, not individuals; see instructions on page 3):  
Exempt payee code (if any) \_\_\_\_\_  
Exemption from Foreign Account Tax Compliance Act (FATCA) reporting code (if any) \_\_\_\_\_  
(Applies to accounts maintained outside the United States.)

**3b** If on line 3a you checked "Partnership" or "Trust/estate," or checked "LLC" and entered "P" as its tax classification, and you are providing this form to a partnership, trust, or estate in which you have an ownership interest, check this box if you have any foreign partners, owners, or beneficiaries. See instructions

**5** Address (number, street, and apt. or suite no.). See instructions.  
**3101 Fit Sport Life Blvd**

**6** City, state, and ZIP code  
**Rockwall, TX 75032**

**7** List account number(s) here (optional)

Requester's name and address (optional)

**Part I Taxpayer Identification Number (TIN)**

Enter your TIN in the appropriate box. The TIN provided must match the name given on line 1 to avoid backup withholding. For individuals, this is generally your social security number (SSN). However, for a resident alien, sole proprietor, or disregarded entity, see the instructions for Part I, later. For other entities, it is your employer identification number (EIN). If you do not have a number, see *How to get a TIN*, later.

**Social security number**

			-			
--	--	--	---	--	--	--

or

**Employer identification number**

8	2	-	4	0	2	2	6	8	1
---	---	---	---	---	---	---	---	---	---

**Note:** If the account is in more than one name, see the instructions for line 1. See also *What Name and Number To Give the Requester* for guidelines on whose number to enter.

**Part II Certification**

Under penalties of perjury, I certify that:

- The number shown on this form is my correct taxpayer identification number (or I am waiting for a number to be issued to me); and
- I am not subject to backup withholding because (a) I am exempt from backup withholding, or (b) I have not been notified by the Internal Revenue Service (IRS) that I am subject to backup withholding as a result of a failure to report all interest or dividends, or (c) the IRS has notified me that I am no longer subject to backup withholding; and
- I am a U.S. citizen or other U.S. person (defined below); and
- The FATCA code(s) entered on this form (if any) indicating that I am exempt from FATCA reporting is correct.

**Certification instructions.** You must cross out item 2 above if you have been notified by the IRS that you are currently subject to backup withholding because you have failed to report all interest and dividends on your tax return. For real estate transactions, item 2 does not apply. For mortgage interest paid, acquisition or abandonment of secured property, cancellation of debt, contributions to an individual retirement arrangement (IRA), and, generally, payments other than interest and dividends, you are not required to sign the certification, but you must provide your correct TIN. See the instructions for Part II, later.

**Sign Here**    Signature of U.S. person    Bradley Stevenson    Date    8/15/2024

**General Instructions**

Section references are to the Internal Revenue Code unless otherwise noted.

**Future developments.** For the latest information about developments related to Form W-9 and its instructions, such as legislation enacted after they were published, go to [www.irs.gov/FormW9](http://www.irs.gov/FormW9).

**What's New**

Line 3a has been modified to clarify how a disregarded entity completes this line. An LLC that is a disregarded entity should check the appropriate box for the tax classification of its owner. Otherwise, it should check the "LLC" box and enter its appropriate tax classification.


New line 3b has been added to this form. A flow-through entity is required to complete this line to indicate that it has direct or indirect foreign partners, owners, or beneficiaries when it provides the Form W-9 to another flow-through entity in which it has an ownership interest. This change is intended to provide a flow-through entity with information regarding the status of its indirect foreign partners, owners, or beneficiaries, so that it can satisfy any applicable reporting requirements. For example, a partnership that has any indirect foreign partners may be required to complete Schedules K-2 and K-3. See the Partnership Instructions for Schedules K-2 and K-3 (Form 1065).

**Purpose of Form**

An individual or entity (Form W-9 requester) who is required to file an information return with the IRS is giving you this form because they



**Exhibit F  
Form 1295**

<b>CERTIFICATE OF INTERESTED PARTIES</b>		<b>FORM 1295</b>	
Complete Nos. 1 - 4 and 6 if there are interested parties. Complete Nos. 1, 2, 3, 5, and 6 if there are no interested parties.		<b>OFFICE USE ONLY</b>	
<b>1 Name of business entity filing form, and the city, state and country of the business entity's place of business.</b> <u>AMERISPORTS LLC</u>			
<b>2 Name of governmental entity or state agency that is a party to the contract for which the form is being filed.</b> <u>City of Rockwall, Texas</u>			
<b>3 Provide the identification number used by the governmental entity or state agency to track or identify the contract, and provide a description of the goods or services to be provided under the contract.</b> <u>TIN 82-4022681</u>			
4 Name of Interested Party	City, State, Country (place of business)	Nature of interest (check applicable)	
		Controlling	Intermediary
<u>PATRICK JAMES</u>	<u>ROCKWALL TX USA</u>	<u>X</u>	
<u>BRAD STEUBSON</u>	<u>HEATH TX USA</u>	<u>X</u>	
<u>JEFF IRVING</u>	<u>WHITE FISH MT USA</u>	<u>X</u>	
<b>5 Check only if there is NO interested party.</b> <input type="checkbox"/>			
<b>6 AFFIDAVIT</b> I swear, or affirm, under penalty of perjury, that the above disclosure is true and correct.			
 Signature of authorized agent of contracting business entity			
AFFIX NOTARY STAMP & SEAL ABOVE			
Sworn to and subscribed before me, by the said _____, this the <u>26</u> day of <u>AUGUST</u> , 20 <u>24</u> , to certify which, witness my hand and seal of office.			
_____ Signature of officer administering oath	_____ Printed name of officer administering oath	_____ Title of officer administering oath	
<b>ADD ADDITIONAL PAGES AS NECESSARY</b>			



City of Rockwall  
*The New Horizon*

---

# Building Inspections Department Monthly Report

---

October 2024

## Permits

<b>Total Permits Issued:</b>	<b>303</b>
Building Permits:	56
Contractor Permits:	247
<b>Total Commercial Permit Values:</b>	<b>\$9,141,529.00</b>
Building Permits:	\$6,526,233.00
Contractor Permits:	\$2,615,296.00
<b>Total Fees Collected:</b>	<b>\$610,616.91</b>
Building Permits:	\$516,449.94
Contractor Permits:	\$94,166.97

## Board of Adjustment

Board of Adjustment Cases: 0

11/26/2024  
8:26:18AM

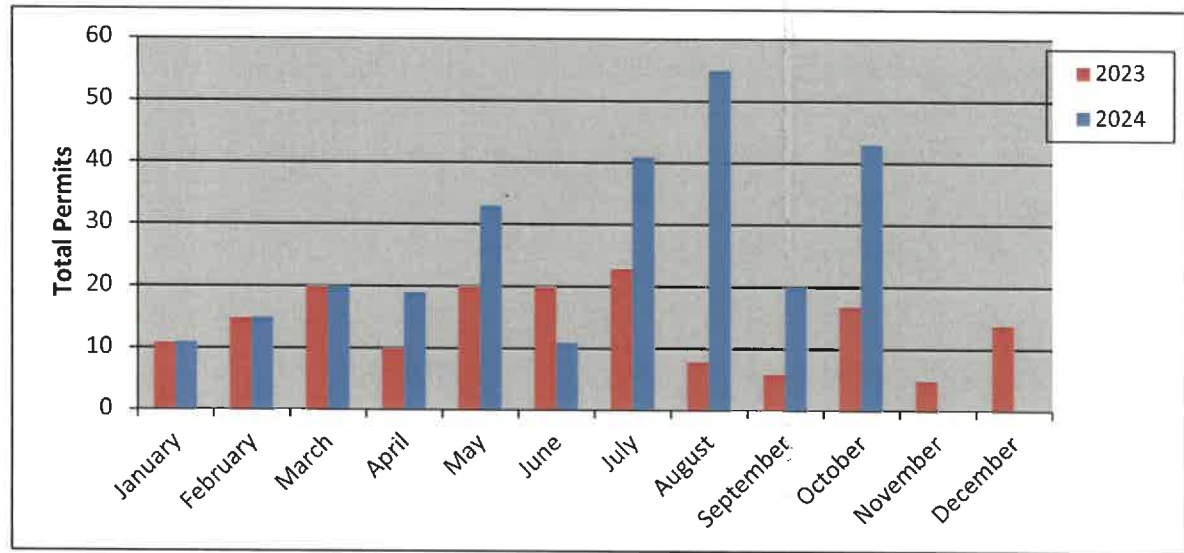
City of Rockwall  
PERMITS ISSUED - Summary by Type and Subtype  
For the Period 10/1/2024 to 10/31/2024

Type/Subtype	# of Permits Issued	Valuation of Work	Fees Charged
Commercial Building Permit	54	\$9,141,529.00	\$263,229.98
Backflow Permit	4	4,800.00	\$299.26
Cell Tower Permit	2	27,000.00	\$493.18
Demolition	1		\$51.00
Electrical Permit	9	83,501.00	\$1,608.13
Irrigation Permit	6		\$47,920.82
Mechanical Permit	2	64,950.00	\$986.44
New Construction	5	6,526,233.00	\$195,153.77
Plumbing Permit	5	6,004.00	\$346.04
Remodel	6	2,393,000.00	\$14,815.84
Sign Permit	13	36,041.00	\$1,453.50
Temporary Construction Trailer	1		\$102.00
Residential Building Permit	245		\$345,346.93
Accessory Building Permit	2		\$906.53
Addition	1		\$127.50
Artificial Turf	1		\$51.00
Concrete Permit	7		\$1,581.41
Deck Permit	2		\$229.50
Driveway Permit	1		\$220.32
Electrical Permit	8		\$709.50
Fence Permit	23		\$1,172.00
Generator	9		\$1,377.00
Irrigation Permit	36		\$2,754.00
Mechanical Permit	19		\$2,320.50
New Single Family Residential	43		\$317,781.50
Outdoor Kitchen Permit	1		\$127.50
Patio Cover/Pergola	7		\$765.00
Plumbing Permit	31		\$2,519.00
Pool	4		\$609.00
Remodel	4		\$1,820.65
Retaining Wall Permit	3		\$204.00
Roofing Permit	19		\$1,452.00
Solar Panel Permit	4		\$1,696.02
Takeline - Boat House	1		\$440.64
Takeline - Seawall	2		\$102.00
Temporary Construction Trailer	1		\$5,565.36
Window & Door Permit	16		\$815.00
Short Term Rental	4		\$2,040.00
Non-Owner-Occupied	4		\$2,040.00
<b>Totals:</b>	<b>303</b>		<b>\$610,616.91</b>

## New Residential Permits

## Calendar Year

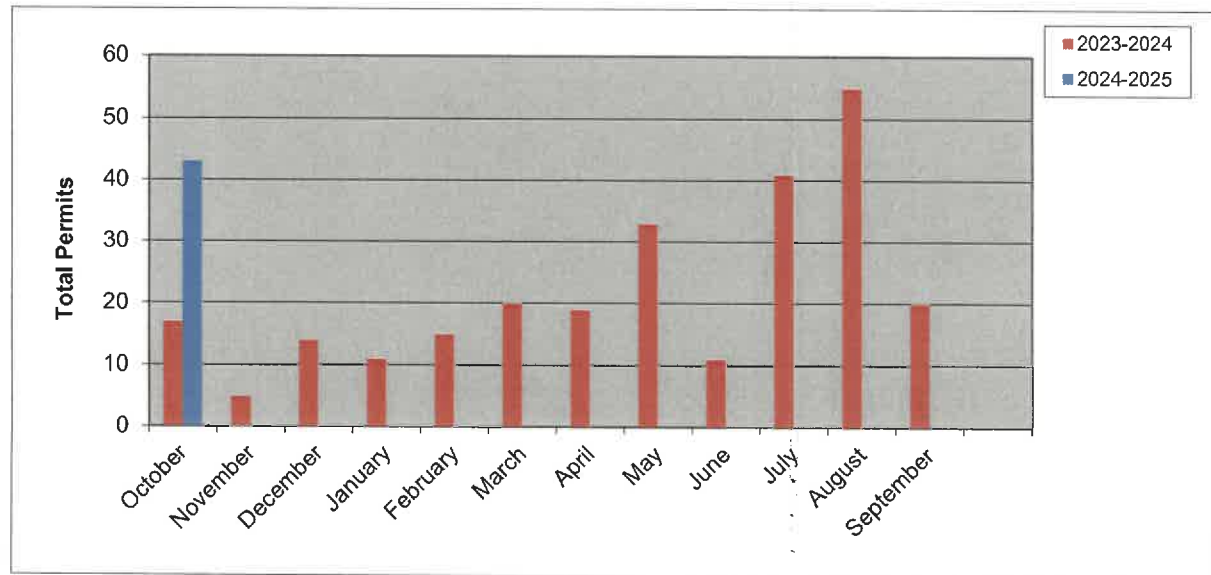
	Year	
	2023	2024
January	11	11
February	15	15
March	20	20
April	10	19
May	20	33
June	20	11
July	23	41
August	8	55
September	6	20
October	17	43
November	5	
December	14	
<b>Totals</b>	<b>169</b>	<b>268</b>



## New Residential Permits

## Fiscal Year

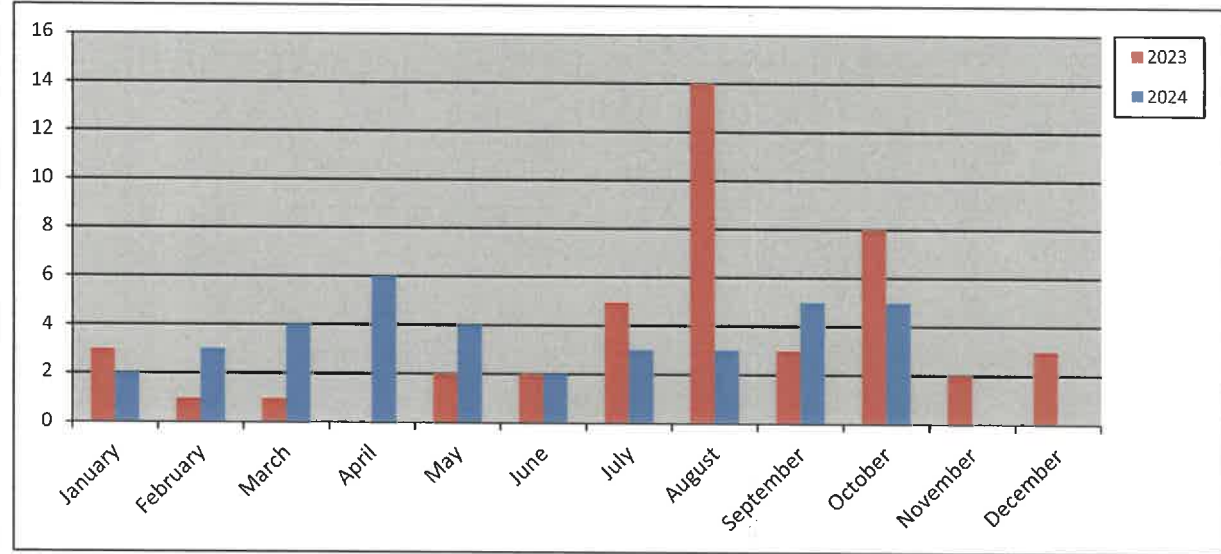
	Year	
	2023-2024	2024-2025
October	17	43
November	5	
December	14	
January	11	
February	15	
March	20	
April	19	
May	33	
June	11	
July	41	
August	55	
September	20	
<b>Totals</b>	<b>261</b>	<b>43</b>



## Residential Remodel/Additions Permits

## Calendar Year

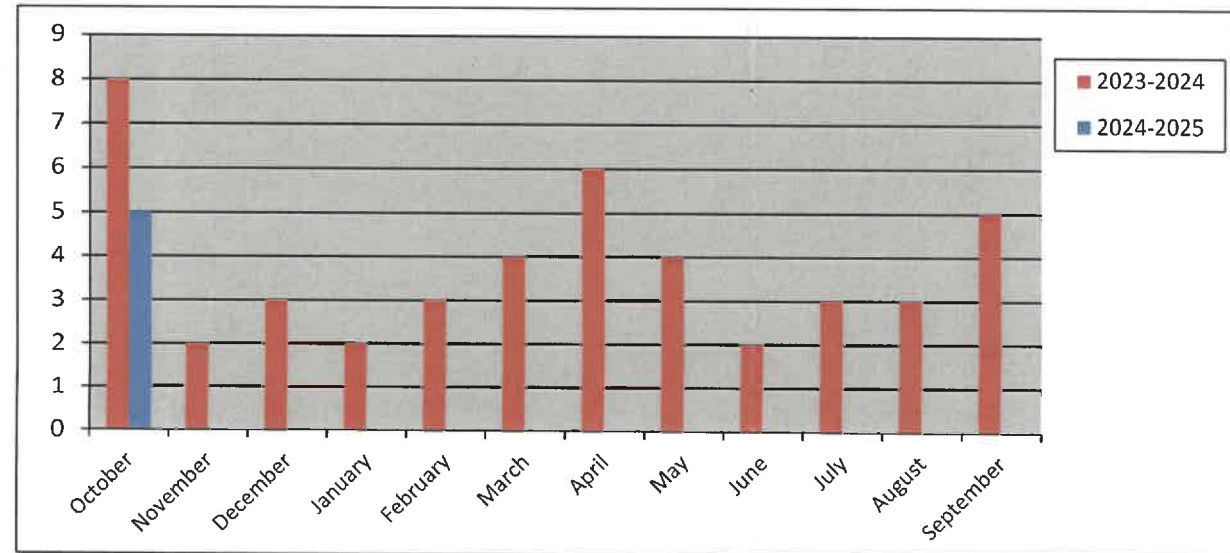
Year		
	2023	2024
January	3	2
February	1	3
March	1	4
April	0	6
May	2	4
June	2	2
July	5	3
August	14	3
September	3	5
October	8	5
November	2	
December	3	
<b>Totals</b>	<b>44</b>	<b>37</b>



## Residential Remodel/Additions Permits

## Fiscal Year

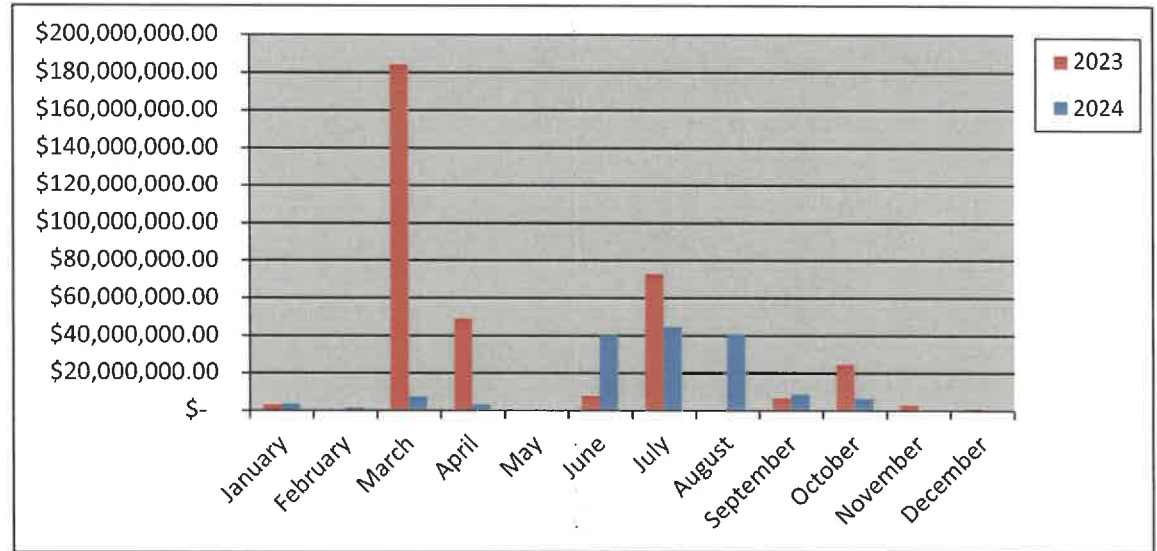
Year		
	2023-2024	2024-2025
October	8	5
November	2	
December	3	
January	2	
February	3	
March	4	
April	6	
May	4	
June	2	
July	3	
August	3	
September	5	
<b>Totals</b>	<b>45</b>	<b>5</b>



**New Commercial Value**

**Calendar Year**

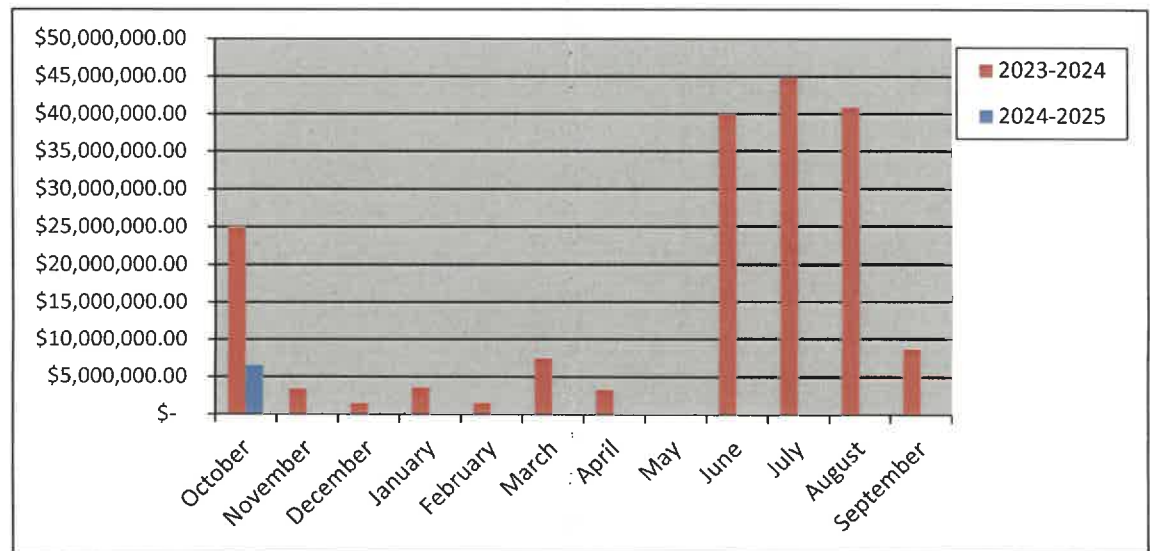
Year		
	2023	2024
January	\$ 3,684,500.00	\$ 3,628,000.00
February	\$ -	\$ 1,600,000.00
March	\$ 184,834,500.00	\$ 7,573,400.00
April	\$ 49,466,652.00	\$ 3,400,000.00
May	\$ -	\$ -
June	\$ 8,450,000.00	\$ 40,015,846.78
July	\$ 73,254,209.00	\$ 44,803,145.65
August	\$ -	\$ 41,008,367.00
September	\$ 7,200,000.00	\$ 8,800,000.00
October	\$ 25,014,439.00	\$ 6,526,233.00
November	\$ 3,500,000.00	
December	\$ 1,539,000.00	
<b>Totals</b>	<b>\$ 356,943,300.00</b>	<b>\$ 157,354,992.43</b>



**New Commercial Value**

**Fiscal Year**

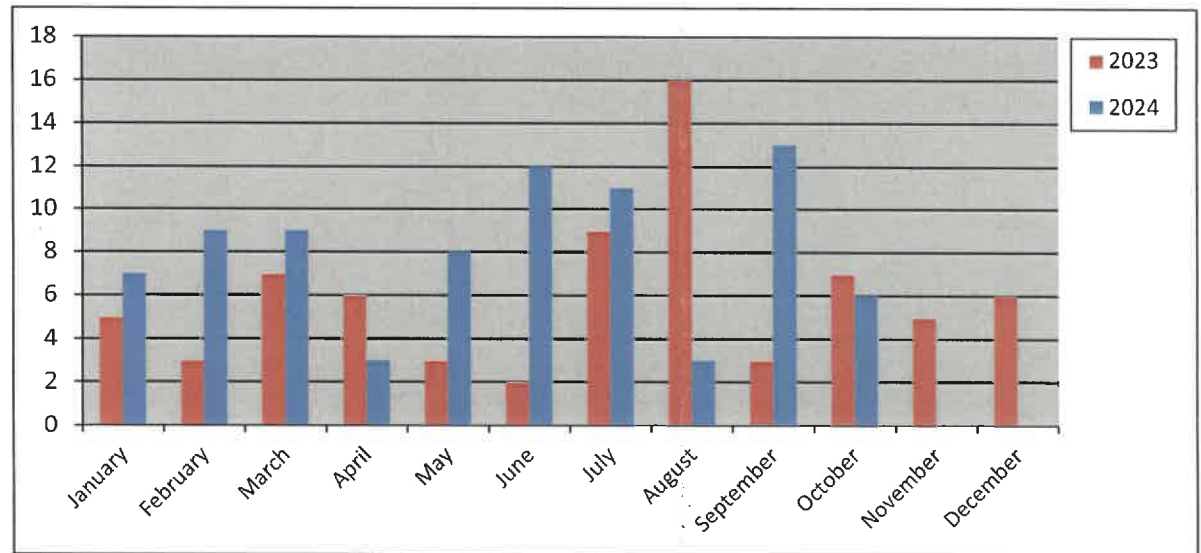
Year		
	2023-2024	2024-2025
October	\$ 25,014,439.00	\$ 6,526,233.00
November	\$ 3,500,000.00	
December	\$ 1,539,000.00	
January	\$ 3,628,000.00	
February	\$ 1,600,000.00	
March	\$ 7,573,400.00	
April	\$ 3,400,000.00	
May	\$ -	
June	\$ 40,015,846.78	
July	\$ 44,803,145.65	
August	\$ 41,008,367.00	
September	\$ 8,800,000.00	
<b>Totals</b>	<b>\$ 180,882,198.43</b>	<b>\$ 6,526,233.00</b>



## Commercial Remodel Permits

## Calendar Year

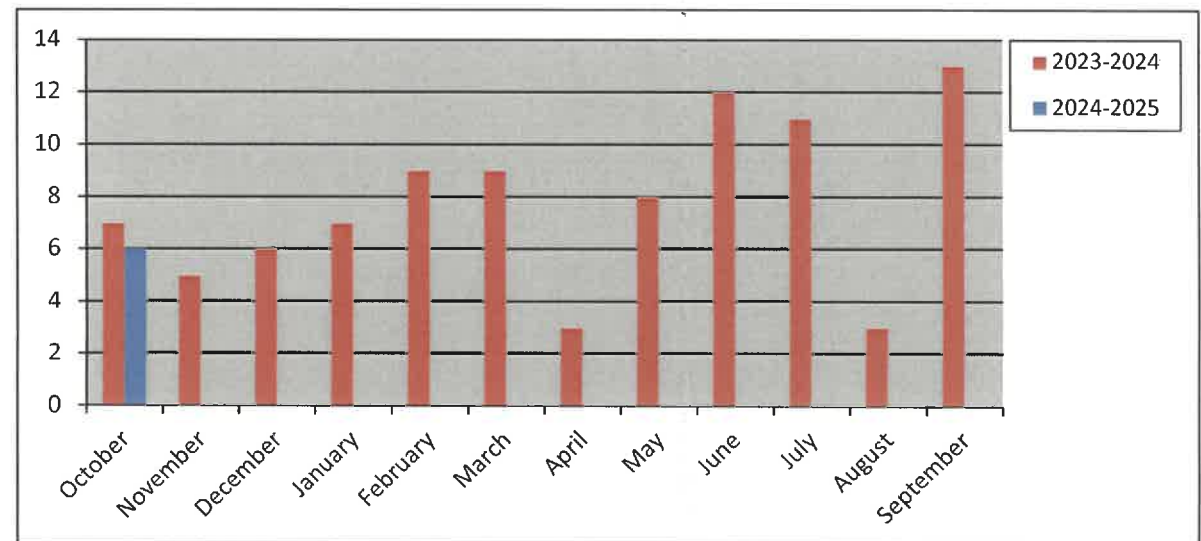
	Year	
	2023	2024
January	5	7
February	3	9
March	7	9
April	6	3
May	3	8
June	2	12
July	9	11
August	16	3
September	3	13
October	7	6
November	5	
December	6	
<b>Totals</b>	<b>72</b>	<b>81</b>



## Commercial Remodel Permits

## Fiscal Year

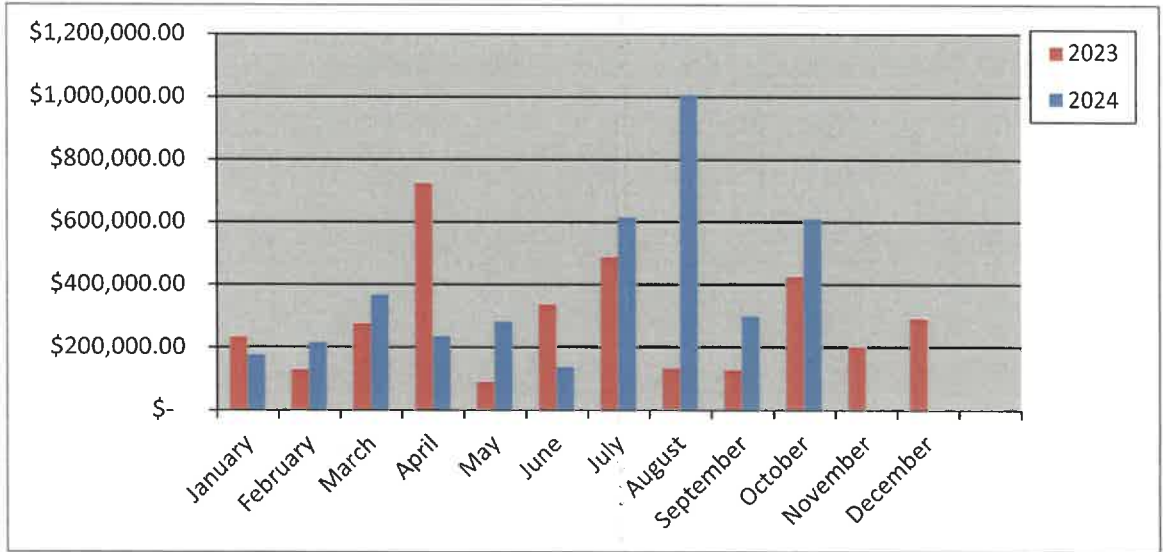
	Year	
	2023-2024	2024-2025
October	7	6
November	5	
December	6	
January	7	
February	9	
March	9	
April	3	
May	8	
June	12	
July	11	
August	3	
September	13	
<b>Totals</b>	<b>93</b>	<b>6</b>



**Total Fees Collected**

**Calendar Year**

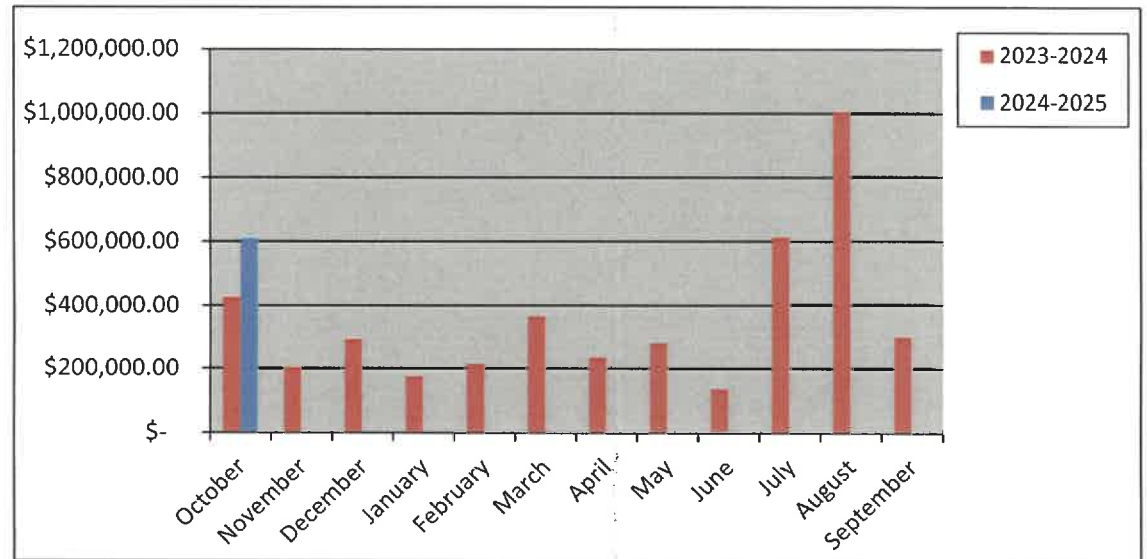
Year		
	2023	2024
January	\$ 235,769.45	\$ 177,441.82
February	\$ 131,295.33	\$ 217,495.76
March	\$ 278,577.39	\$ 368,481.32
April	\$ 727,627.76	\$ 236,650.24
May	\$ 91,036.40	\$ 283,718.89
June	\$ 338,892.45	\$ 137,783.50
July	\$ 491,588.49	\$ 615,851.86
August	\$ 135,201.61	\$ 1,007,731.91
September	\$ 129,729.04	\$ 300,912.22
October	\$ 428,622.49	\$ 610,616.91
November	\$ 204,858.87	
December	\$ 295,452.22	
<b>Totals</b>	<b>\$ 3,488,651.50</b>	<b>\$ 3,956,684.43</b>



**Total Fees Collected**

**Fiscal Year**

Year		
	2023-2024	2024-2025
October	\$ 428,622.49	\$ 610,616.91
November	\$ 204,858.87	
December	\$ 295,452.22	
January	\$ 177,441.82	
February	\$ 217,495.76	
March	\$ 368,481.32	
April	\$ 236,650.24	
May	\$ 283,718.89	
June	\$ 137,783.50	
July	\$ 615,851.86	
August	\$ 1,007,731.91	
September	\$ 300,912.22	
<b>Totals</b>	<b>\$ 4,275,001.10</b>	<b>\$ 610,616.91</b>





CERTIFICATES OF OCCUPANCY ISSUED

For the Period 10/1/2024 to 10/31/2024

Permit Number	Permit Type	Site Address	Total Fees	
Application Date	Subtype	Parcel Number	Total SQFT	Fees Paid
Issue Date	Status of Permit	Subdivision Name		
	Business Name	Plan Number	Valuation	
CO2024-134	Certificate of Occupancy			
07/25/2024		1785 E Interstate 30, 107,	\$76.50	\$76.50
10/14/2024	ISSUED	Rockwall, TX, 75087		
	Bobby's Garage & Mobile Service			

Contact Type	Contact Name Business Phone	Contact Address	Valuation	TX	75087
Applicant	Bobby Haney	10821 E catfish dr	Wills point	Tx	75169
Business Owner	Bobby Haney	1785 E Interstate 30, 107	Rockwall	TX	75087
Property Owner	Middlebrooks Holding LLC	1785 E. interstate 30	Rockwall	Tx	75086
Inspection Report C	Bobby Haney	10821 E Catfish dr	Wills point	TX	75169

Contractors

CO2024-136	Certificate of Occupancy			
08/06/2024		112 E RUSK ST,	\$75.00	\$75.00
10/23/2024	ISSUED	ROCKWALL, TX 75087		
	BELLE VIE BISTRO			

Contact Type	Contact Name Business Phone	Contact Address	Valuation	TX	75087
Applicant	NURIA HERNANDEZ	112 E RUSK ST	Rockwall	TX	75087
Business Owner	NURIA HERNANDEZ 469-750-1222	112 E RUSK ST	ROCKWALL	TX	75087
Property Owner	JHON / MD REAL ESTAT	2500 DISCOVERY BLVD	Rockwall	TX	75087
Inspection Report C	NURIA HERNANDEZ	112 E RUSK ST	Rockwall	TX	75087

Contractors

CO2024-156	Certificate of Occupancy			
09/13/2024		1023 E INTERSTATE 30,	\$76.50	\$76.50
10/17/2024	ISSUED	ROCKWALL, TX 75032		
	Canales Furniture			

CERTIFICATES OF OCCUPANCY ISSUED

For the Period 10/1/2024 to 10/31/2024

Permit Number	Permit Type	Site Address		Total Fees
Application Date	Subtype	Parcel Number		
Issue Date	Status of Permit	Subdivision Name		
	Business Name	Plan Number	Valuation	Total SQFT
Contact Type	Contact Name Business Phone	Contact Address		Fees Paid
Applicant	Yenice Villeda	639 Mohan Dr	Royse City TX	75189
Business Owner	Yenice Villeda 682-777-8330	1019 E Interstate 30, 1023	Rockwall TX	75032
Property Owner	CTO Realty Growth Inc	1140 N Williamson Blvd	Daytona Beach FL	32114
Inspection Report C	Yenice Villeda	639 Mohan Dr	Royse City TX	75189

Contractors

---

CO2024-160	Certificate of Occupancy			\$76.50	\$76.50
09/17/2024		427 E INTERSTATE 30,			
10/14/2024	ISSUED	ROCKWALL, TX, 75087			
	Gold Star Nails				

Contact Type	Contact Name Business Phone	Contact Address			
Applicant	TRISH NGUYEN	131 GLENWOOD DR	MURPHY TX	75094	
Business Owner	TRISH NGUYEN	427 E INTERSTATE 30	MURPHY TX	75087	
Property Owner	CARLA VISNICK, SENIO	16475 DALLAS PARKWAY, SUITE 800	ADDISION TX	75001	
Inspection Report C	Trish Nguyen	427 E I-30	Rockwall TX	75087	

Contractors

---

CO2024-168	Certificate of Occupancy			\$76.50	\$76.50
10/11/2024		1010 W RALPH HALL			
10/25/2024	ISSUED	PKWY, S. 200,			
	Lamberth Ratcliffe Covington PLLC	ROCKWALL, TX, 75032			

Contact Type	Contact Name Business Phone	Contact Address			
Applicant	Clay Spicer	4210 Ridge Road, Suite #201	Heath TX	75032	
Business Owner	Brad Lamberth	1010 W Ralph Hall Pkwy, Suite #200	Rockwall TX	75032	
Property Owner	Andy Qualls	1010 W Ralph Hall Pkwy	Rockwall, TX TX	75032	
Inspection Report C	Clay Spicer	4210 Ridge Road, Suite #201	Heath TX	75032	

Contractors

CERTIFICATES OF OCCUPANCY ISSUED

For the Period 10/1/2024 to 10/31/2024

Permit Number	Permit Type	Site Address	Total Fees
Application Date	Subtype	Parcel Number	
Issue Date	Status of Permit	Subdivision Name	
	Business Name	Plan Number	Valuation
			Total SQFT
			Fees Paid
CO2024-8	Certificate of Occupancy		
01/09/2024			\$126.50
10/15/2024	ISSUED	196 RANCH TRL, ROCKWALL, TX 75032	\$76.50
	Mpact Dance Studio		

Contact Type	Contact Name	Contact Address			
	Business Phone				
Applicant	Mallory Mills	196 Ranch Trail Dr	Rockwall	TX	75032
Business Owner	Mallory Mills 469-338-0145	196 Ranch Trail Dr	Rockwall	TX	75032
Property Owner	HomeBank Texas	601 N Hwy 175	Seagoville	TX	75159
Inspection Report C	Mallory Mills	196 Ranch Trail Dr	Rockwall	TX	75032

Contractors

TCO2024-164	Temporary Certificate of Occupancy		
09/27/2024		1600 JUSTIN RD	\$306.00
10/10/2024	ISSUED		\$306.00
	Channell Commercial Corp		

Contact Type	Contact Name	Contact Address			
	Business Phone				
Applicant	Kara Balderas	1600 Justin Rd	Rockwall	TX	75087
Business Owner	William Channell 214-304-7800	1700 Justin Rd	Rockwall	TX	75087
Property Owner	Willcar Holdings	1700 Justin Rd	Rockwall	TX	75087
Inspection Report C	Alton Frazier	1600 Justin Rd	Rockwall	TX	75087
Inspection Report C	Ed Burke	1600 Justin Rd	Rockwall	TX	75087

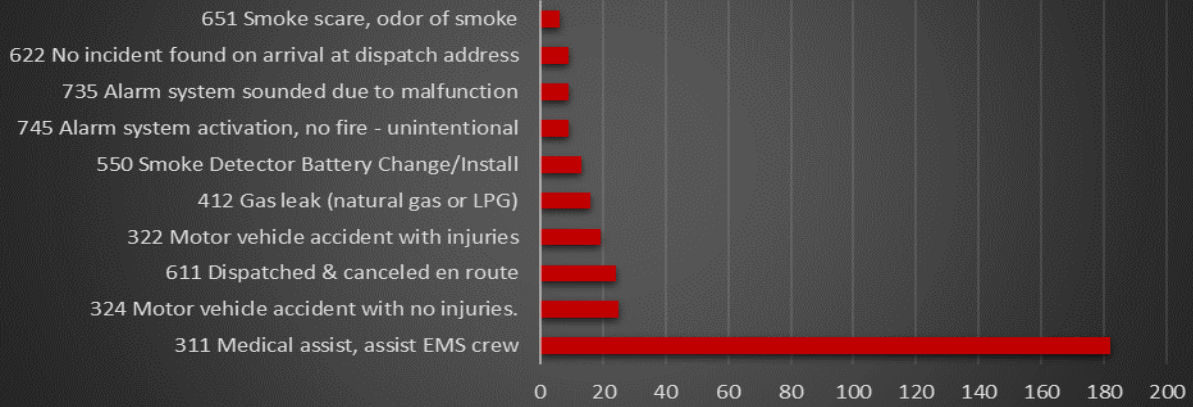
Contractors

**Total Valuation:**  
**Total Fees: \$813.50**  
**Total Fees Paid: \$763.50**



October 2024  
Monthly Report

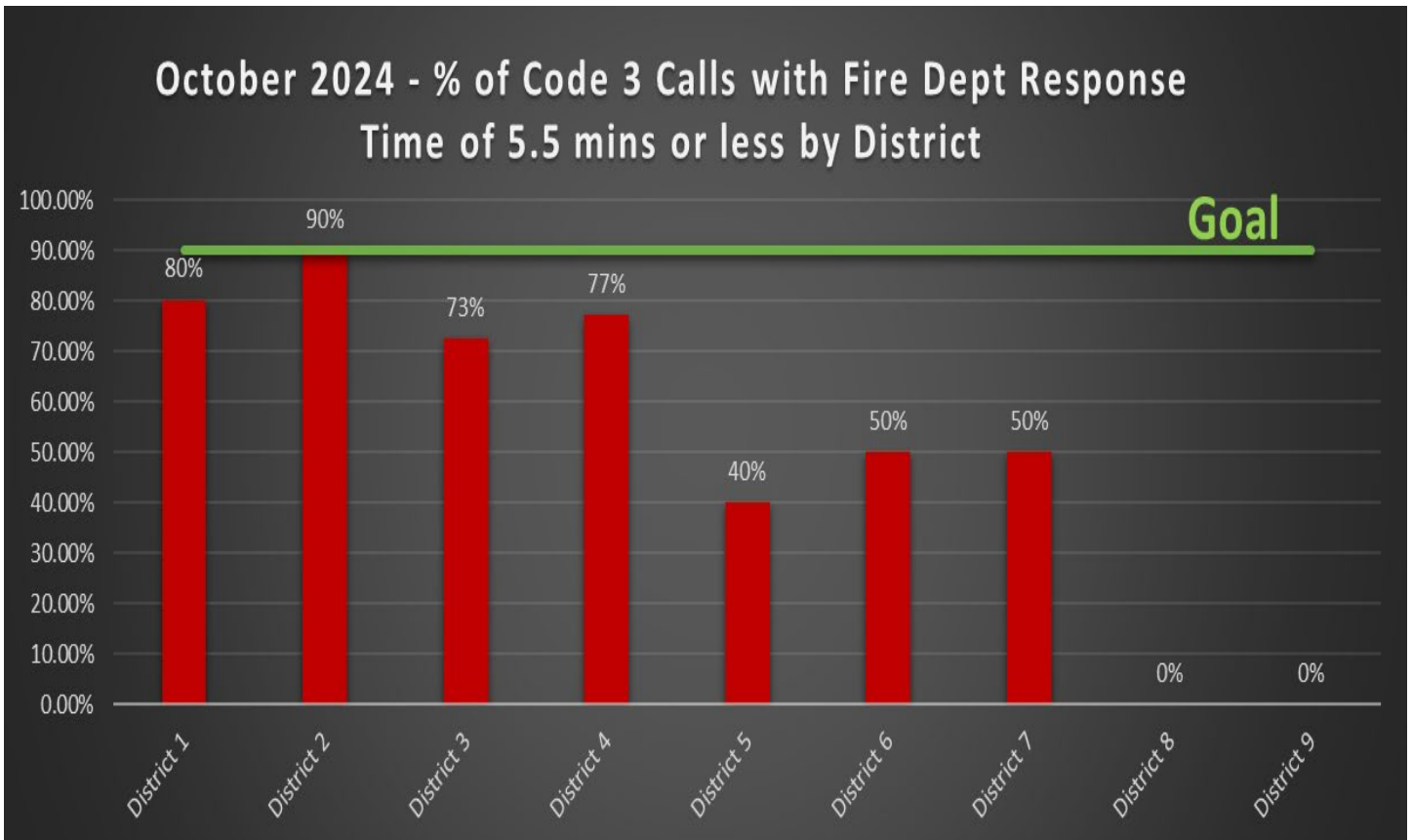
## Top 10 NFIRS Call Types



All Calls By NFIRS Call Type	Incident Count
111 Building fire	1
131 Passenger vehicle fire (cars, pickups, SUV's)	2
150 OTHER Outside rubbish fire	1
151 Outside rubbish, trash or waste fire	4
251 Excessive heat, scorch burns with no ignition	1
311 Medical assist, assist EMS crew	182
322 Motor vehicle accident with injuries	19
323 Motor vehicle/pedestrian accident (MV Ped)	2
324 Motor vehicle accident with no injuries.	25
331 Lock-in (if lock out , use 511 )	2
352 Extrication of victim(s) from vehicle	1
353 Removal of victim(s) from stalled elevator	1
360 Water & ice-related rescue, other	1
411 Gasoline or other flammable liquid spill	2
412 Gas leak (natural gas or LPG)	16
424 Carbon monoxide incident	1
442 Overheated motor	1
463 Vehicle accident, general cleanup	2
500 Service Call, other	1
511 Lock-out	2
522 Water or steam leak	3
531 Smoke or odor removal	1
542 Animal rescue	2
550 Public service assistance, other	5
550 Smoke Detector Battery Change/Install	13
551 Assist police or other governmental agency	1
553 Public service	3
600 Good intent call, other	1
611 Dispatched & canceled en route	24
622 No incident found on arrival at dispatch address	9
651 Smoke scare, odor of smoke	6
653 Smoke from barbecue, tar kettle	1
700 False alarm or false call, other	4
710 Malicious, mischievous false call, other	1
711 Municipal alarm system, malicious false alarm	1
730 System malfunction, other	1
733 Smoke detector activation due to malfunction	3
735 Alarm system sounded due to malfunction	9
736 CO detector activation due to malfunction	4
740 Unintentional transmission of alarm, other	2
741 Sprinkler activation, no fire - unintentional	2
743 Smoke detector activation, no fire - unintentional	1
745 Alarm system activation, no fire - unintentional	9
746 Carbon monoxide detector activation, no CO	2
900 Special type of incident, other	2
<b>Grand Total</b>	<b>377</b>

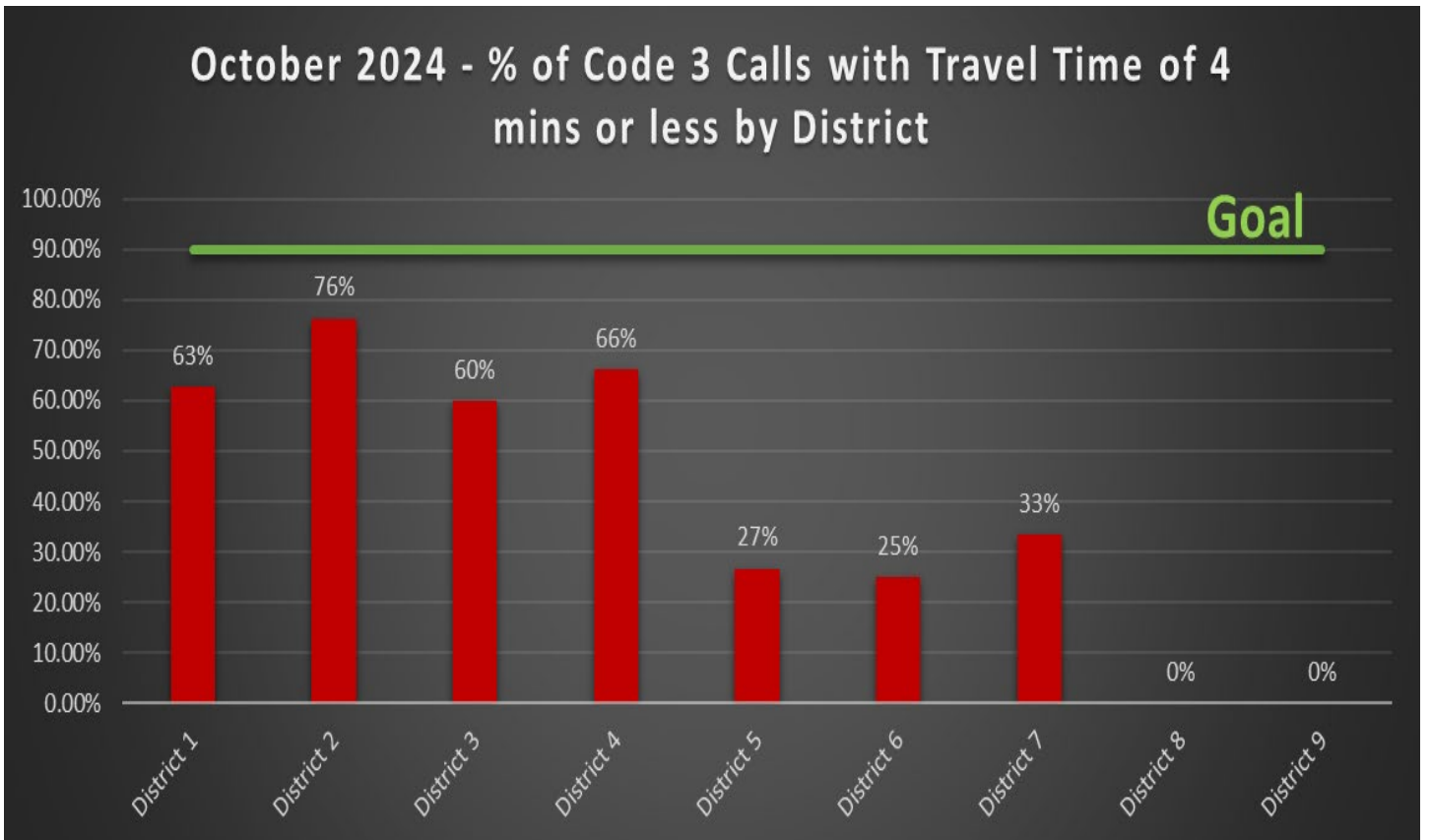
## October 2024 Dispatch to Arrival Analysis

District	Total Number of Calls	Percent of Runs per District	Number of Calls in 5.5 mins or Less	Average FD Response Time Minutes	% in 5.5 min or less	Goal of 90%
District 1	91	31%	73	0:04:34	80%	90%
District 2	80	27%	72	0:03:55	90%	90%
District 3	40	13%	29	0:04:44	73%	90%
District 4	53	18%	41	0:04:34	77%	90%
District 5	15	5%	6	0:05:26	40%	90%
District 6	4	1%	2	0:05:43	50%	90%
District 7	12	4%	6	0:06:01	50%	90%
District 8	1	0%	0	0:05:35	0%	90%
District 9	2	1%	0	0:09:26	0%	90%
<b>Department</b>	<b>298</b>	<b>100%</b>	<b>229</b>	<b>0:04:34</b>	<b>77%</b>	<b>90%</b>



## October 2024 Travel Times by District

District	Total Number of Calls	Percent of Runs per District	Number of Calls in 4 or Less	Average Travel Time Minutes	% in 4 min or less	Goal of 90%
District 1	91	31%	57	0:03:43	63%	90%
District 2	80	27%	61	0:03:09	76%	90%
District 3	40	13%	24	0:03:58	60%	90%
District 4	53	18%	35	0:03:39	66%	90%
District 5	15	5%	4	0:04:39	27%	90%
District 6	4	1%	1	0:05:05	25%	90%
District 7	12	4%	4	0:05:13	33%	90%
District 8	1	0%	0	0:05:22	0%	90%
District 9	2	1%	0	0:08:34	0%	90%
<b>Department</b>	<b>298</b>	<b>100%</b>	<b>186</b>	<b>0:03:45</b>	<b>62%</b>	<b>90%</b>





# Total Dollar Losses

October 2024



City of Rockwall  
*The New Horizon*

Rockwall Fire Department

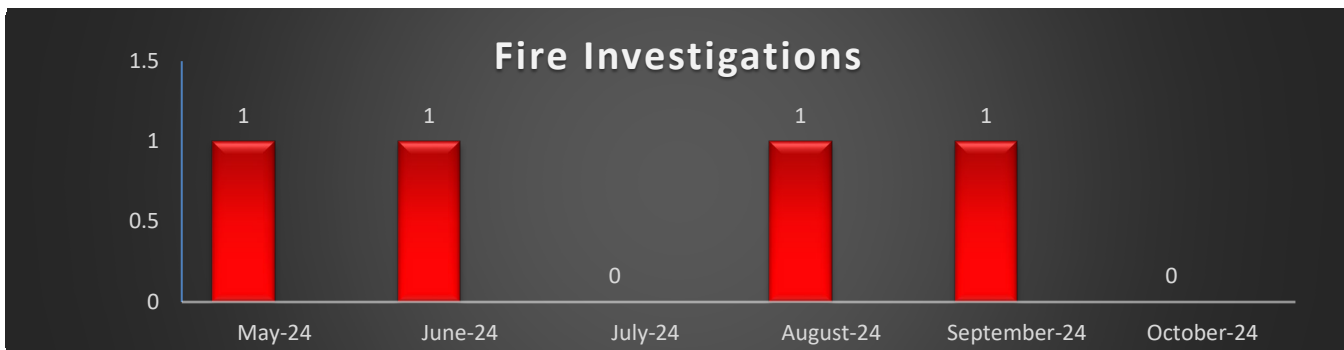
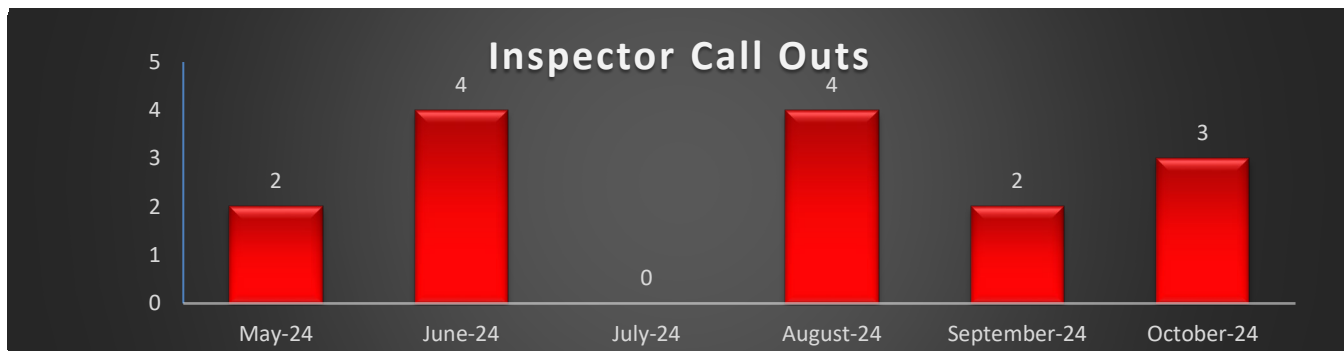
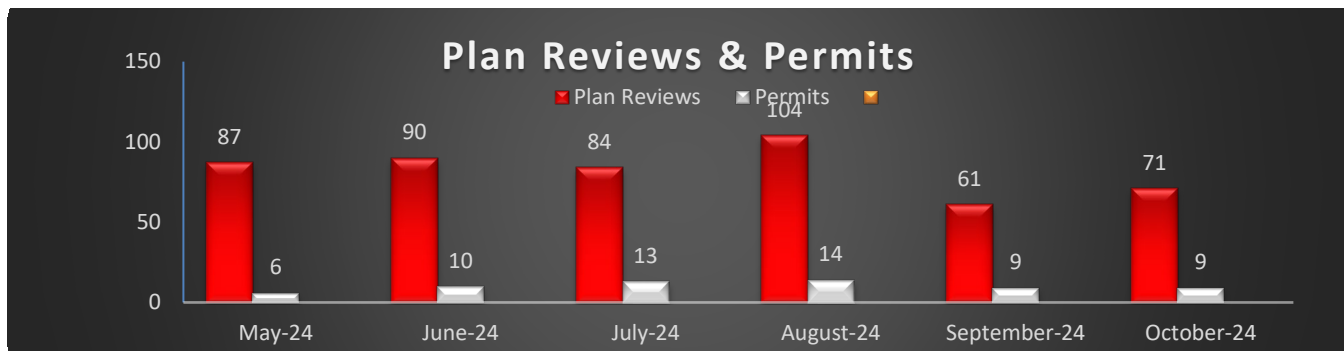
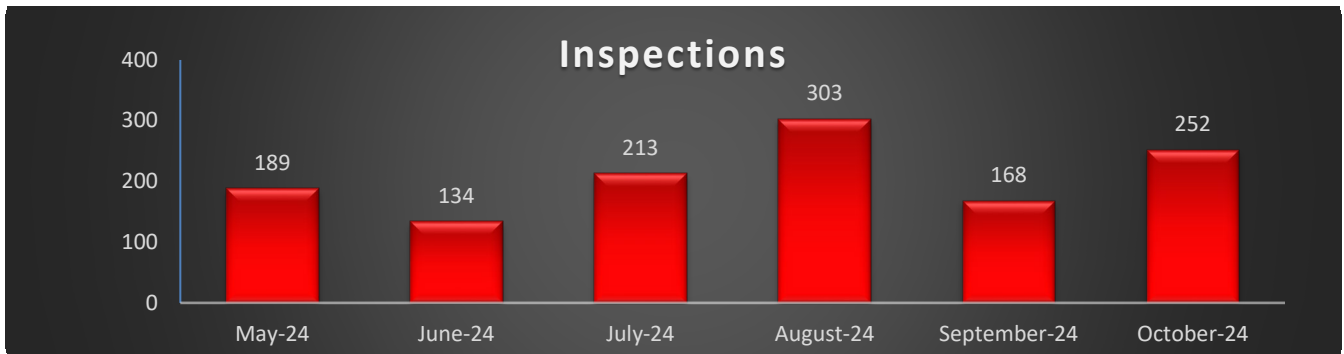
Print Date/Time: 11/15/2024 09:15  
Login ID: rck\dgang  
Layer: All  
Areas: All

ORI Number: TX504  
Incident Type: All  
Station: All

	Current Month	Last Month	Same Month Last Year	Year To Date	Last Year To Date
<b>Total Property Loss:</b>	\$0.00	\$30,000.00	\$1,500.00	\$144,000.00	\$1,639,250.32
<b>Total Content Loss:</b>	\$0.00	\$2,000.00	\$1,000.00	\$48,000.00	\$2,050,173.75
<b>Total Property Pre-Incident Value:</b>	\$0.00	\$436,500.00	\$409,525.00	\$1,633,253.64	\$117,658,943.32
<b>Total Contents Pre-Incident Value</b>	\$0.00	\$261,900.00	\$75,000.00	\$695,207.78	\$24,803,920.19
<b>Total Losses:</b>	\$0.00	\$32,000.00	\$2,500.00	\$192,000.00	\$0.00
<b>Total Value:</b>	\$0.00	\$698,400.00	\$484,525.00	\$2,328,461.42	\$142,462,863.51



# Fire Prevention, Education, & Investigations Division Monthly Report October 2024





# Monthly Report October 2024



RIB RUB RUN & ROLL  
5000 ATTENDEES



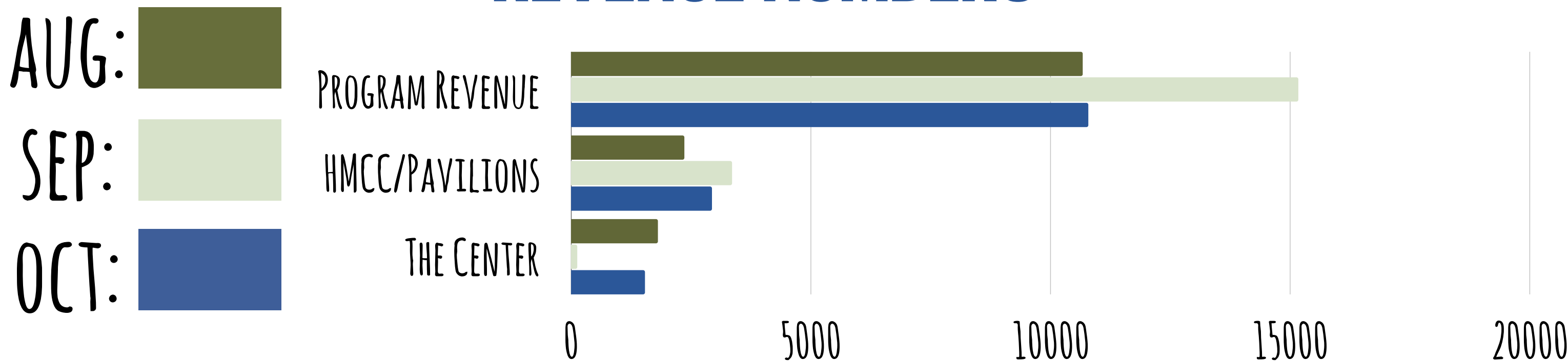
OCTOBER SENIOR LUNCHEON  
51 ATTENDEES



SCARE ON THE SQUARE  
4000 ATTENDEES



## REVENUE NUMBERS



## Other Events:

<b>Harmony at The Harbor</b>	<b>October 10, 17, 24</b>
<b>October Senior Luncheon</b>	<b>October 4</b>
<b>Little Kickers</b>	<b>October &amp; November</b>

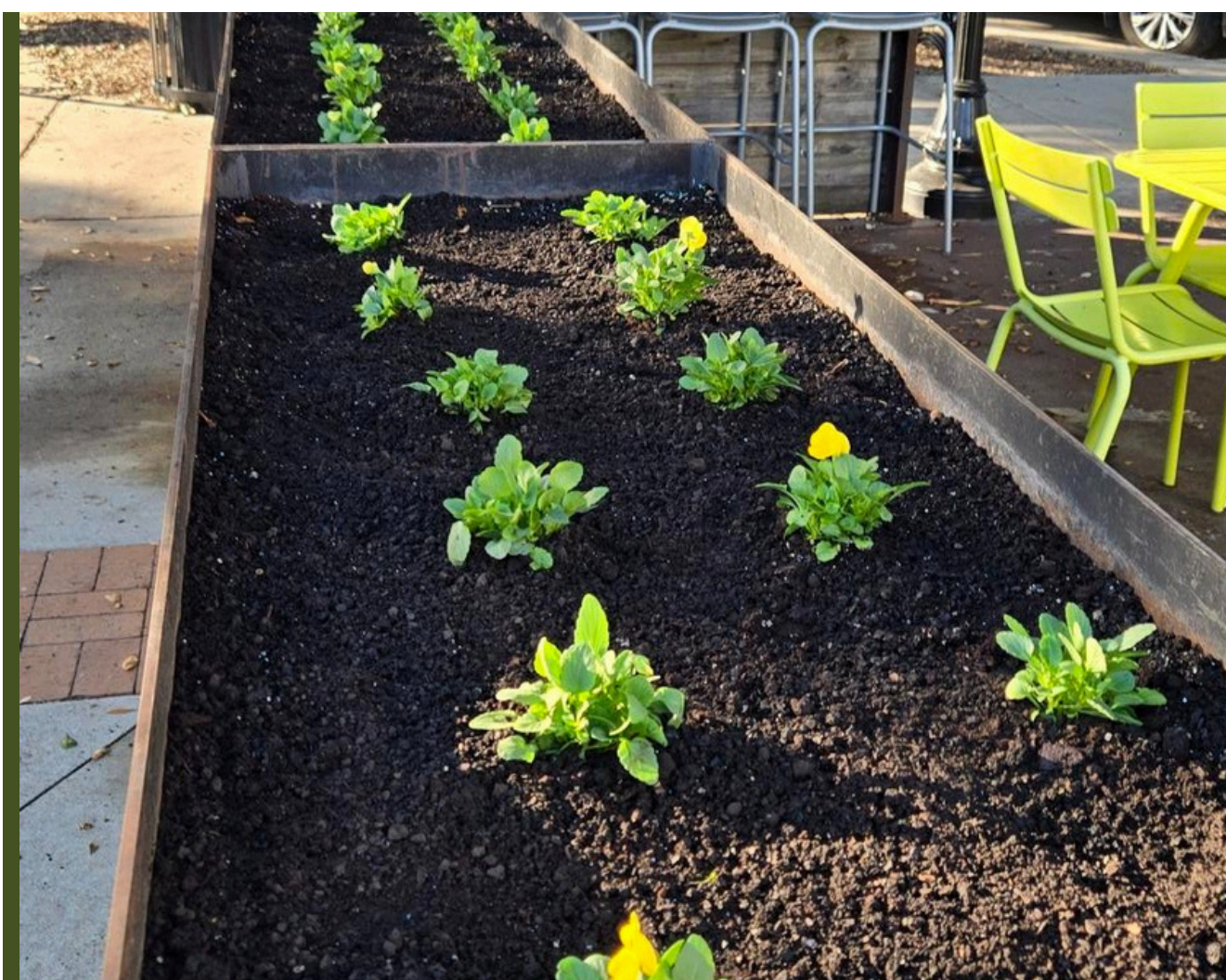
# PARKS PROJECT UPDATE – OCTOBER 2024



DRY RIVERBED BETWEEN CITY HALL  
AND THE CENTER



TURF ESTABLISHMENT AT DOG PARK



ANNUAL PLANTING OF VIOLAS



EAGLE SCOUT PROJECT AT STONE CREEK  
BUTTERFLY GARDEN

## Other Projects

IRRIGATION MAIN LINE REPAIRS AT TUTTLE  
TREE REPLACEMENT AT SAN JACINTO PLAZA

# Rockwall Police Department

## Monthly Activity Report

October-2024

ACTIVITY	CURRENT MONTH <b>OCTOBER</b>	PREVIOUS MONTH <b>SEPTEMBER</b>	<b>YTD 2024</b>	<b>YTD 2023</b>	<b>YTD % CHANGE</b>
----------	---------------------------------	------------------------------------	---------------------	---------------------	-------------------------

### PART 1 OFFENSES

Homicide / Manslaughter	1	0	1	0	<b>100.00%</b>
Sexual Assault	1	2	11	9	<b>22.22%</b>
Robbery	2	0	7	9	<b>-22.22%</b>
Aggravated Assault	6	8	45	19	<b>136.84%</b>
Burglary	2	9	52	32	<b>62.50%</b>
Larceny	55	40	474	496	<b>-4.44%</b>
Motor Vehicle Theft	3	5	31	63	<b>-50.79%</b>
<b>TOTAL PART I</b>	<b>70</b>	<b>64</b>	<b>621</b>	<b>628</b>	<b>-1.11%</b>
<b>TOTAL PART II</b>	<b>109</b>	<b>128</b>	<b>1098</b>	<b>1198</b>	<b>-8.35%</b>
<b>TOTAL OFFENSES</b>	<b>179</b>	<b>192</b>	<b>1719</b>	<b>1826</b>	<b>-5.86%</b>

### ADDITIONAL STATISTICS

FAMILY VIOLENCE	13	25	164	93	<b>76.34%</b>
D.W.I.	18	22	137	133	<b>3.01%</b>

### ARRESTS

FELONY	19	24	216	255	<b>-15.29%</b>
MISDEMEANOR	66	67	518	511	<b>1.37%</b>
WARRANT ARREST	6	5	72	71	<b>1.41%</b>
JUVENILE	4	11	57	48	<b>18.75%</b>
<b>TOTAL ARRESTS</b>	<b>95</b>	<b>107</b>	<b>863</b>	<b>885</b>	<b>-2.49%</b>

### DISPATCH

CALLS FOR SERVICE	2235	1980	22997	24520	<b>-6.21%</b>
-------------------	------	------	-------	-------	---------------

### ACCIDENTS

INJURY	4	2	19	12	<b>58.33%</b>
NON-INJURY	128	81	1160	932	<b>24.46%</b>
FATALITY	0	0	1	4	<b>-75.00%</b>
<b>TOTAL</b>	<b>132</b>	<b>83</b>	<b>1180</b>	<b>948</b>	<b>24.47%</b>

### FALSE ALARMS

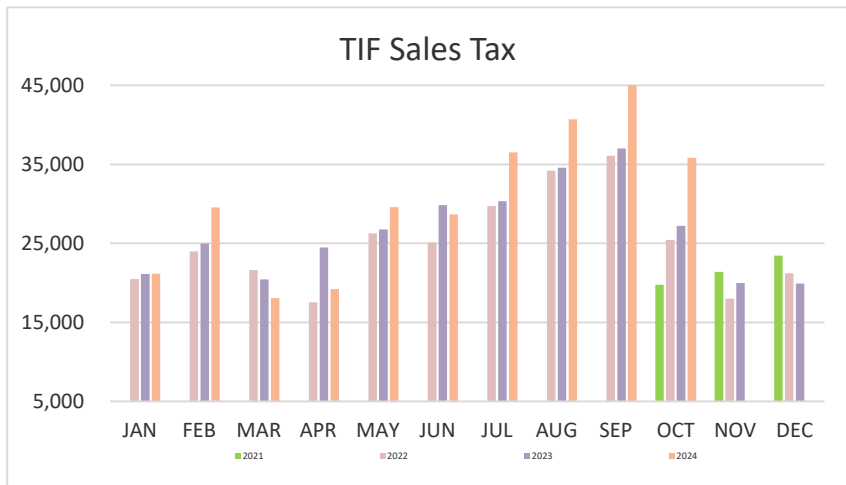
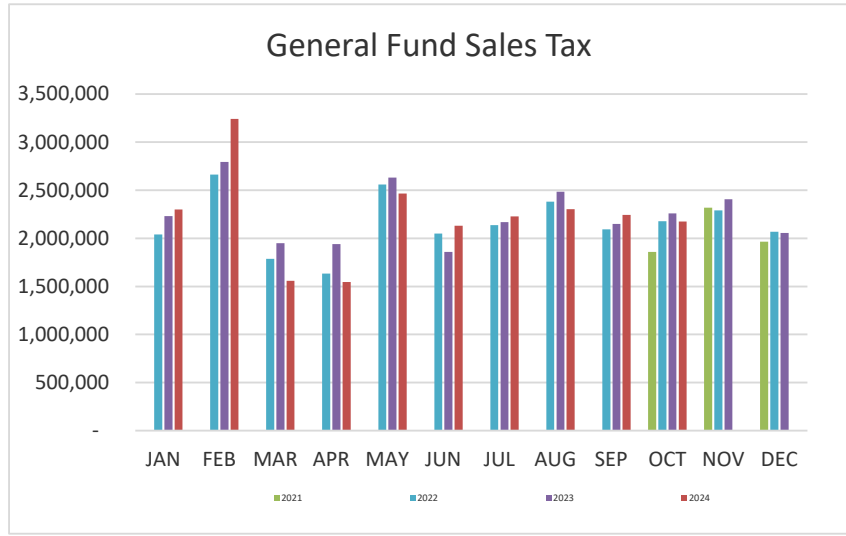
RESIDENT ALARMS	32	38	412	455	<b>-9.45%</b>
BUSINESS ALARMS	132	119	1389	1493	<b>-6.97%</b>
<b>TOTAL FALSE ALARMS</b>	<b>164</b>	<b>157</b>	<b>1801</b>	<b>1948</b>	<b>-7.55%</b>
<b>Estimated Lost Hours</b>	<b>108.24</b>	<b>103.62</b>	<b>1188.66</b>	<b>1285.68</b>	<b>-7.55%</b>
<b>Estimated Cost</b>	<b>\$2,574.80</b>	<b>\$2,464.90</b>	<b>\$28,275.70</b>	<b>\$30,583.60</b>	<b>-7.55%</b>

### ROCKWALL NARCOTICS UNIT

<b>Number of Cases</b>	<b>4</b>
<b>Arrests</b>	<b>5</b>
<b>Arrest Warrants</b>	<b>3</b>
<b>Search Warrants</b>	<b>2</b>
<b>Seized</b>	
Psilocybin	28 grams
Heroin	10 grams
Dangerous Drugs/Fentanyl	35000 grams
Weapons	6
Stolen Property	3 items recovered

# Sales Tax Collections - Rolling 36 Months

	General Fund Sales Tax	TIF Sales Tax
Nov-21	2,317,862	21,385
Dec-21	1,963,345	23,464
Jan-22	2,040,002	20,495
Feb-22	2,664,185	23,976
Mar-22	1,786,902	21,605
Apr-22	1,633,850	17,548
May-22	2,559,349	26,254
Jun-22	2,050,066	25,127
Jul-22	2,135,457	29,738
Aug-22	2,381,510	34,190
Sep-22	2,092,217	36,105
Oct-22	2,177,040	25,420
Nov-22	2,291,130	17,990
Dec-22	2,068,593	21,213
Jan-23	2,231,654	21,134
Feb-23	2,792,696	24,982
Mar-23	1,949,994	20,438
Apr-23	1,938,490	24,487
May-23	2,631,033	26,766
Jun-23	1,859,485	29,862
Jul-23	2,169,495	30,350
Aug-23	2,483,321	34,558
Sep-23	2,149,947	37,018
Oct-23	2,260,609	27,209
Nov-23	2,407,536	19,977
Dec-23	2,054,537	19,906
Jan-24	2,300,943	21,155
Feb-24	3,243,321	29,558
Mar-24	1,559,068	18,064
Apr-24	1,544,681	19,220
May-24	2,464,214	29,570
Jun-24	2,130,506	28,658
Jul-24	2,229,321	36,518
Aug-24	2,301,556	40,719
Sep-24	2,244,383	47,289
Oct-24	2,175,761	35,830



**Notes:**  
 75% of total sales tax collected is deposited to the General Fund each month  
 Comptroller tracks sales tax generated in the TIF and reports it monthly  
 75% of TIF sales tax (city share) is pledged to the TIF

# Monthly Water Consumption - Rolling 27 Months

	<u>Total Gallons</u>	<u>Daily Average</u>	<u>Maximum Day</u>
Aug-22	534,145,350	17,230,494	23,206,750
Sep-22	434,247,536	14,474,915	17,617,728
Oct-22	421,229,833	13,588,058	17,692,206
Nov-22	228,795,657	7,626,522	11,187,251
Dec-22	249,341,535	8,043,275	12,260,392
Jan-23	243,528,725	7,855,765	11,040,666
Feb-23	198,103,255	7,075,116	8,544,708
Mar-23	220,326,930	7,107,320	10,825,669
Apr-23	292,874,560	9,762,486	13,280,734
May-23	355,482,851	11,467,189	16,032,988
Jun-23	491,086,630	16,369,555	21,693,510
Jul-23	587,439,800	18,949,672	23,599,534
Aug-23	742,795,770	23,961,154	25,727,492
Sep-23	637,062,410	21,235,410	31,876,280
Oct-23	461,067,498	14,873,145	20,317,822
Nov-23	307,169,395	10,238,981	12,875,885
Dec-23	277,770,415	8,960,337	13,375,678
Jan-24	326,749,166	10,540,296	21,931,696
Feb-24	236,310,098	8,148,624	10,720,500
Mar-24	270,997,608	8,741,858	10,729,160
Apr-24	292,285,444	9,742,848	11,333,764
May-24	314,251,314	10,137,140	13,475,962
Jun-24	452,670,816	15,089,026	22,364,746
Jul-24	643,093,680	20,744,956	25,259,696
Aug-24	716,579,590	23,115,472	25,942,998
Sep-24	564,519,530	18,817,318	22,530,378
Oct-24	604,424,870	19,497,576	23,874,820

Source: SCADA Monthly Reports generated at the Water Pump Stations

